

SS792HPGD



SAFARI ARMAX SNORKEL

To Suit: Toyota LandCruiser 70 series MY24 Facelift
2.8L 4CYL Turbo Diesel (1GD-FTV Engine) 09/23 - Onwards
4.2L Diesel (1HZ Engine) 09/23 - Onwards

Fits Both Factory & Non-Factory Fitted Raised Air Intake Vehicles

Not compatible with (LC78) Troop Carrier Non-Factory Fitted Raised Air Intake Vehicle Models



01/12/2024

Parts List

ITEM	PART NO	DESCRIPTION	QTY
1	334-133-600	BODY - SNORKEL (SS792HP)	1
2	000-135-980	4" AIR RAM ASSEMBLY	1
3	334-032-100	BRACKET - UPPER MOUNTING	1
4	334-435-000	GASKET - RUBBER - UPPER MOUNTING BRACKET	1
5	334-032-200	BRACKET - REAR MOUNTING (LOWER)	1
6	000-002-100	BOLT - HEX - 6mm x 14mm x 1.0 - SEMS	2
7	000-038-450	BOLT - TORX SCREW - 6mm x 1.0 x 12mm - Black S/S	2
8	000-951-480	SCREW - S/T - 4.2mm x 13mm	4
9	000-442G	GROMMET - M8 - RUBBER	1
10	000-442S	FERRULE - M8 x 11.15mm Long - S/S	1
11	000-110	STUD - 8mm x 1.25 x 25mm - S/S	5
12	000-311-300	WASHER - BODY - 8mm x 30mm - S/S	6
13	000-205-300	NUT - NYLOC - 8mm x 1.25mm - S/S	6

14	000-042-520	BOLT – HEX DRIVE – 8.0mm x 1.25 x 20mm (Black)	2
15	000-042-530	BOLT – HEX DRIVE – 8.0mm x 1.25 x 30mm (Black)	1
16	000-954-400	RIVET NUT – 8.0mm x 1.25 x 17.5mm – STEEL Z/P	2
17	334-992-000	SPACER – 8.5mm x 30mm x 3.0mm – BLACK	1
18	334-024-700	HOSE - AIR ENTRY	1
19	334-217-700	TEMPLATE - AIR CLEANER HOUSING (Rear)	1
20	334-217-725	TEMPLATE - AIR CLEANER HOUSING (Side)	1
21	334-217-750	TEMPLATE - AIR CLEANER HOUSING (Lower)	1
22	334-025-700	PLATE - HOSE SUPPORT - Main Rear	1
23	334-025-725	PLATE - HOSE SUPPORT - Side Upper	1
24	334-025-750	PLATE - HOSE SUPPORT - Lower Corner	1
25	334-025-775	PLATE - HOSE SUPPORT - Lower	1
26	334-025-800	PLATE - HOSE SUPPORT - Rear Lower	1
27	000-958-175	POP RIVET - 4mm x 17mm	17
28	334-031-700	BRACKET - AIR CLEANER MOUNTING	1
29	000-1022-300	BOLT - B/H - 5mm - S/S	3
30	000-320-350	WASHER - BODY - 5.0mm x 15MM - S/S	6
31	000-221-300	NUT - NYLOC - 5mm - S/S	3
32	000-1912	CLAMP - HOSE - 110/130mm - S/S	1
33	334-017-600	TEMPLATE - GUARD PANEL	1



SS792HPGD

SAFARI ARMAX SNORKEL

To Suit: Toyota LandCruiser 70 series MY24 Facelift
2.8L 4CYL Turbo Diesel (1GD-FTV Engine) 09/23 - Onwards
4.2L Diesel (1HZ Engine) 09/23 – Onwards

Fits Both Factory & Non-Factory Fitted Raised Air Intake Vehicles

Not compatible with (LC78) Troop Carrier Non-Factory Fitted Raised Air Intake Vehicle Models

Installation Guide

Fitment to:

- Right Hand Side

Fitting Time:

- 180 min

Special Tools:

- Body Saw (Reciprocating)
- Rivet Nut Gun
- Step Drill
- Loctite 243 (Thread Lock)
- 6mm Spot Weld Drill / 6.5mm Drill bit
- 2, 9, 10 & 11mm Drill Bits
- T30 Torx Drive
- Files / Grinder
- Masking Tape
- Touch-up Paint
- Sikaflex 227 Adhesive Sealant

Prior to commencing the installation, it is the installer's responsibility to verify that all components and particularly the guard panel template (Item 33) are correct.

1

Remove the following in accordance with the factory service manual:

- Air Cleaner Assembly

2

Remove and discard the perforated section from the guard panel template (Item 33) as shown.

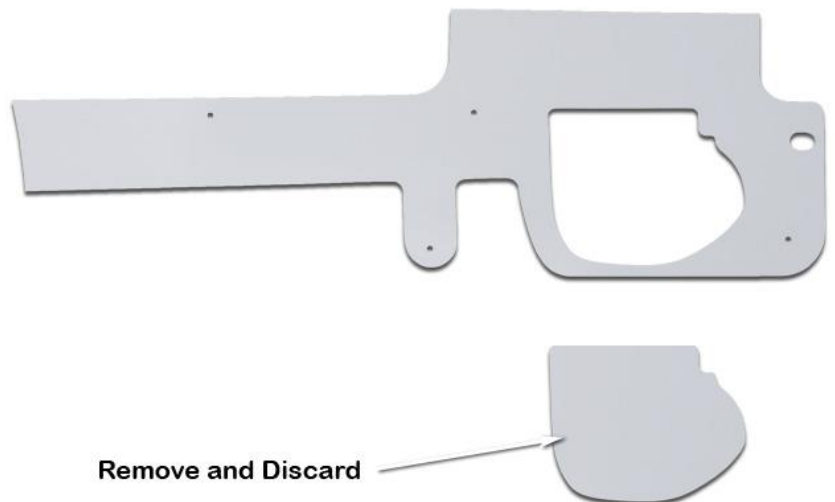

Factory Fitted Raised Air Intake Vehicles:

Follow steps 3 – 10.

(For Non-Factory Fitted Raised Air Intake Vehicles Skip to Steps 11 – 21)

3

Remove and discard the Factory Toyota Raised Air Intake components (shown).

The following hardware must be retained,

- x2 A-pillar bracket mounting bolt assemblies (20mm long)
- Rear mounting bolt assembly (30mm long).



4

The front factory captive mounting nut assembly must be removed from the front RH guard panel.

The assembly is spot welded to the guard panel in two places. Firstly, identify where the assembly has been spot welded to the guard panel as the position of the spot welds may vary from vehicle to vehicle.

Drill a pilot hole in the centre of each spot weld and drill out the spot welds using a 6.5mm drill bit or spot weld drill bit. Use a small pry bar or flat blade screwdriver, on the backside of the guard panel, to break the spot welds from the guard panel and remove the nut assembly

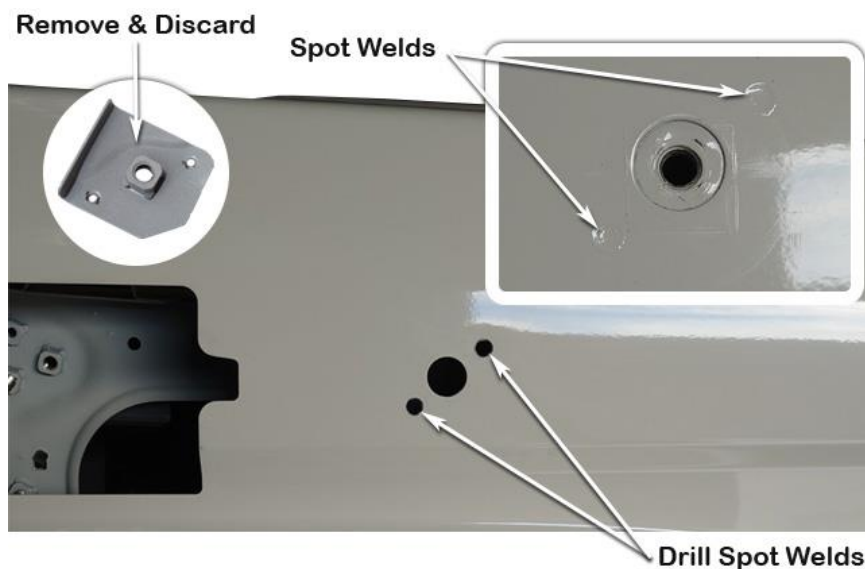

Align the guard panel template (Item 33) to the rear edge and upper edge of the guard panel.

Ensure to align the rear edge of the front template slot to the rear edge of the 18mm Dia. front factory hole of the guard panel as shown.

Tape the template to the guard panel with masking tape.

Mark all four hole positions, the snorkel body outlet hole and the front slot with a felt tip pen.

Remove the template.

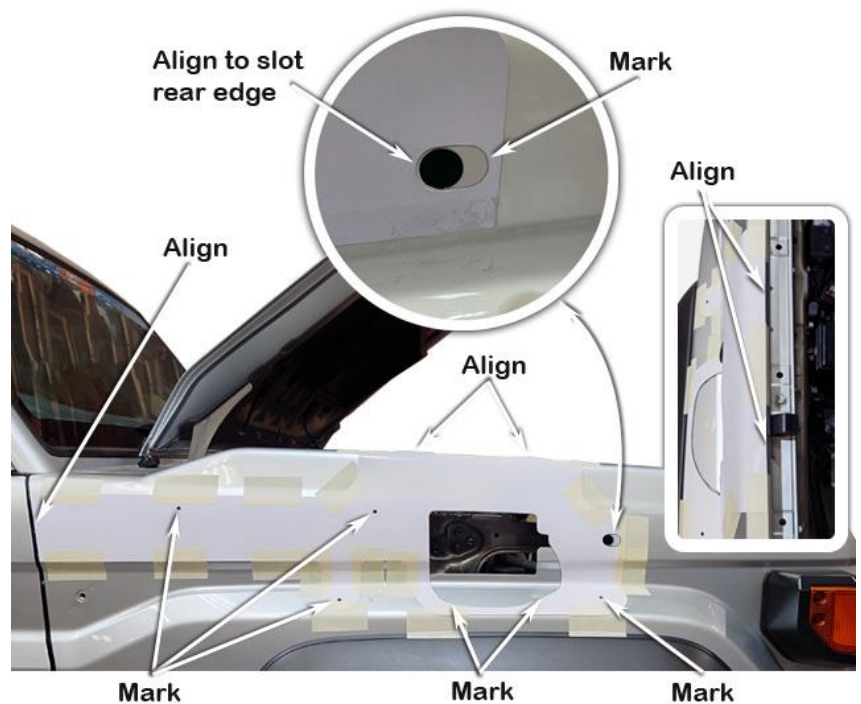

Drill a pilot hole at each of the marked hole positions.

Use a step drill to drill the four mounting hole positions to 16mm diameter.

Use a body saw to cut the marked snorkel body outlet section & front marked slot on the guard panel as shown.

Deburr and paint all holes and cut sections of guard panel to prevent rust.

Hint: If the vehicle is fitted with flares, prior to any cutting or drilling, place a strip of masking tape along the flare seal and guard panel to prevent metal filings being trapped between the seal and guard panel.

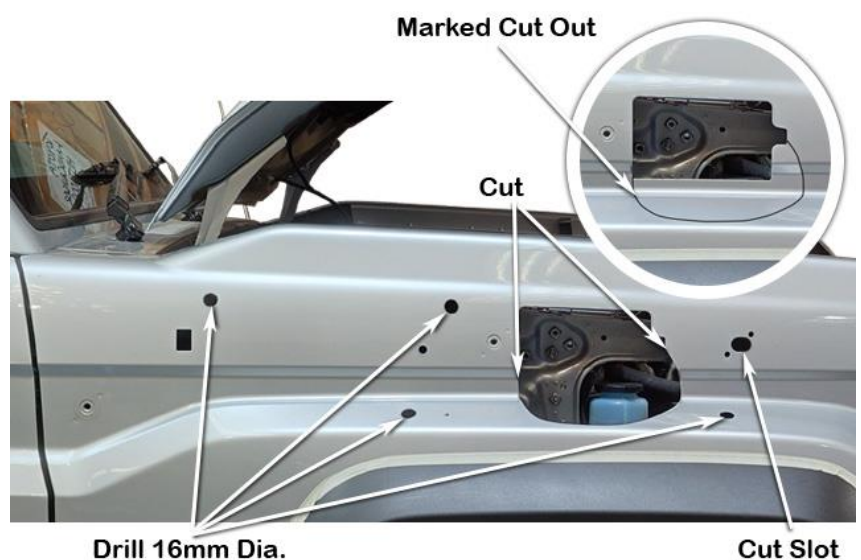

Locate the four dimples around the inlet of the Snorkel body (Item 1).

Drill a 2.0mm hole at each of the four dimple locations as shown.

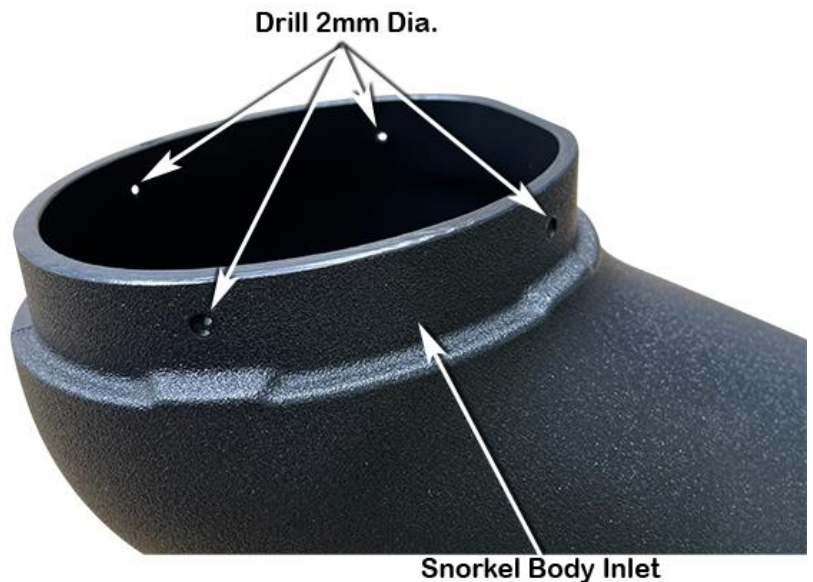

Install the upper mounting bracket (Item 3) to the snorkel body (Item 1), with the M6 Hex SEMS Bolts (Item 6).

Align the upper mounting bracket (Item 3) in the relief as shown and finger tighten the M6 Hex SEMS bolts (Item 6).

Apply Loctite 243 to each of the stainless-steel mounting studs (Item 11) and install the studs finger tight into the snorkel body (Item 1) mounting inserts as shown.

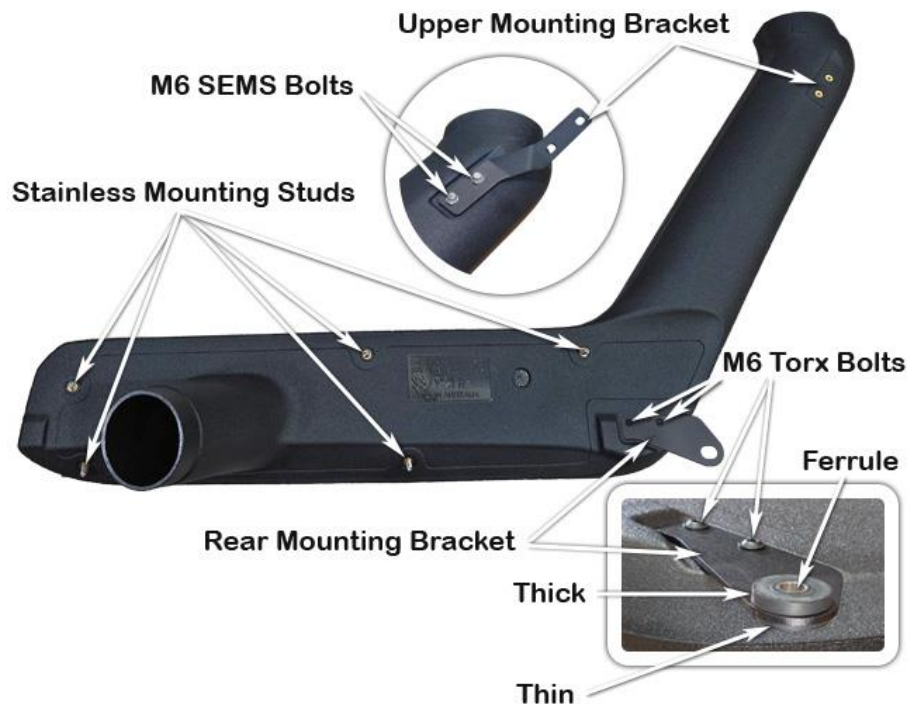

Apply Loctite 243 to the two M6 x 12mm Torx bolts (Item 7) and secure the Rear Mounting Bracket (Item 5) to the Snorkel Body (Item 1) as shown.

Install the rubber grommet (Item 9) into the Rear Mounting Bracket (Item 5) with the thicker side of the grommet facing the panel/backside side of the snorkel body.

Install the stainless-steel ferrule (Item 10) into the grommet as shown.

Carefully install the snorkel body (Item 1) to the guard panel.

When correctly aligned, fasten the snorkel body to the guard panel with the body washers (Item 12) and nyloc nuts (Item 13).

Fasten the rear mounting bracket (Item 5) using the 30mm long genuine Toyota rear mounting bolt assembly retained in step 2.



Position the rubber bracket gasket (Item 4) between the upper mounting bracket (Item 3) and A 'Pillar panel. Ensure gasket is aligned to the x2 factory captive nut locations in the vehicle A 'Pillar.

Secure the upper mounting bracket (Item 3) to the A 'Pillar using the x2 20mm long genuine Toyota A-pillar bracket mounting bolts retained in Step 2.



Non- Factory Raised Air Intake Vehicles:

Follow steps 11 – 21.

11

Align the guard panel template (Item 33) to the rear edge and upper edge of the guard panel.

Tape the template to the guard panel with masking tape.

Mark all four hole positions, the snorkel body outlet hole and the front slot with a felt tip pen.

Remove the template.

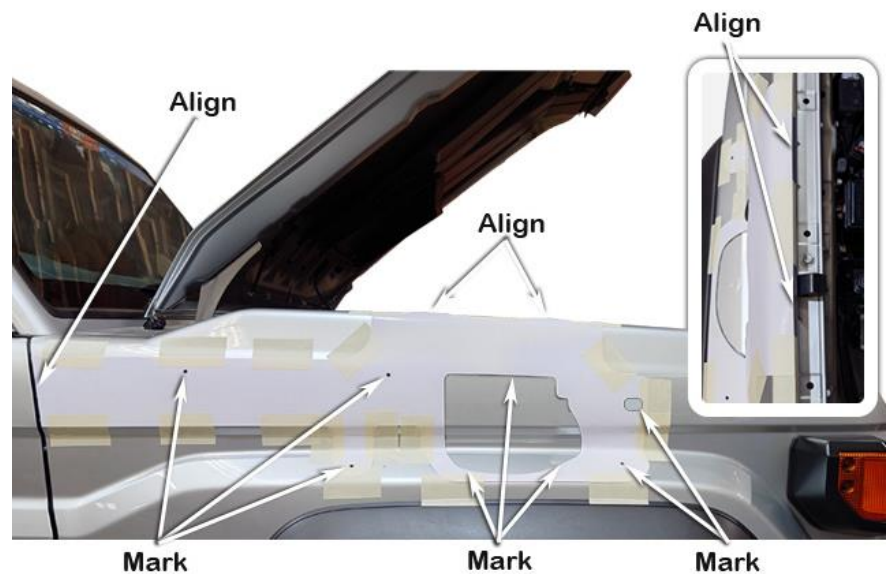

12

Drill a pilot hole at each of the marked hole positions.

Use a step drill to drill the four mounting hole positions to 16mm diameter.

Drill 1 or 2, 10mm diameter holes in the snorkel body outlet section & front marked slot as start/stop points for the body saw.

Use a body saw to cut the marked snorkel body outlet section & front marked slot on the guard panel as shown.

Deburr and paint all holes and cut sections of guard panel to prevent rust.

Hint: Prior to any cutting or drilling, place a strip of masking tape along the flare seal and guard panel to prevent metal filings being trapped between the seal and guard panel.

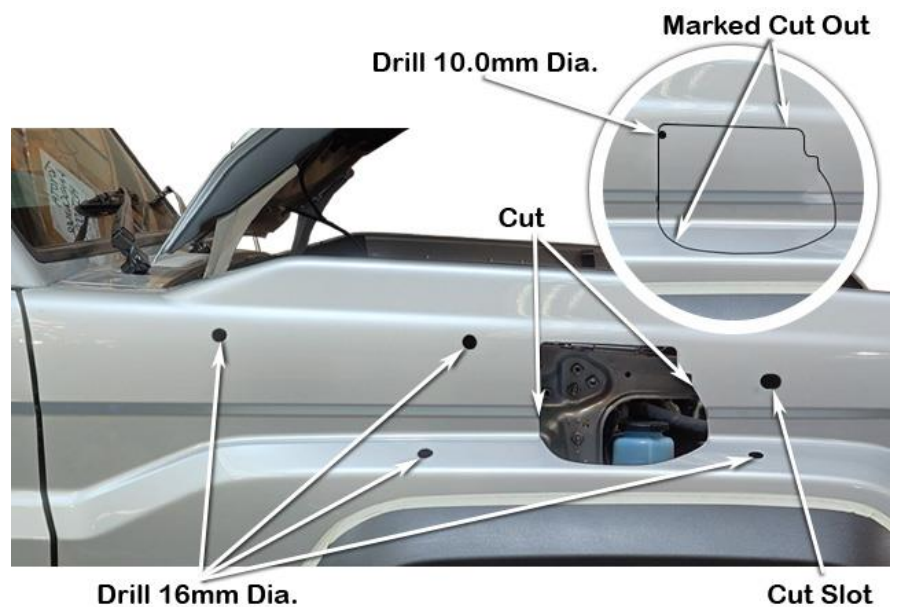

Locate the four dimples around the inlet of the Snorkel body (Item 1).

Drill a 2.0mm hole at each of the four dimple locations as shown.

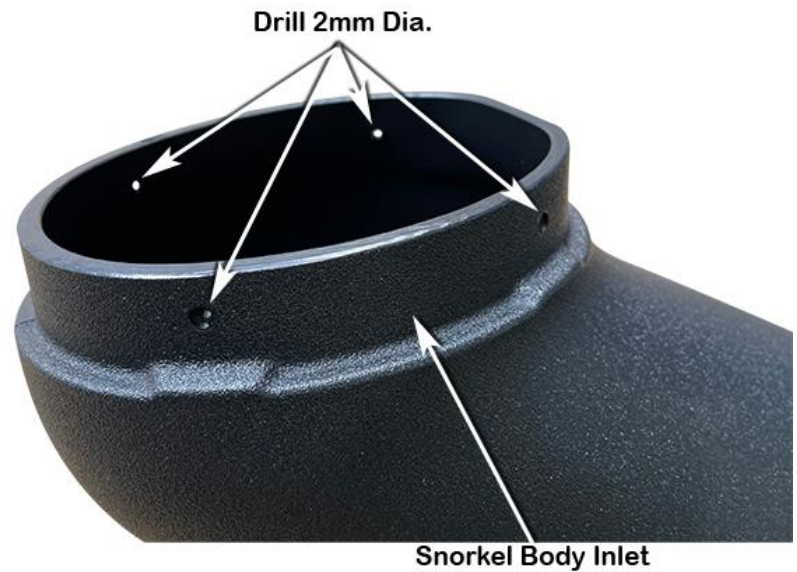

Install the upper mounting bracket (Item 3) to the snorkel body (Item 1), with the M6 Hex SEMS Bolts (Item 6).

Align the upper mounting bracket (Item 3) in the relief as shown and finger tighten the M6 Hex SEMS bolts (Item 6).

Apply Loctite 243 to each of the stainless-steel mounting studs (Item 11) and install the studs finger tight into the snorkel body (Item 1) mounting inserts as shown.

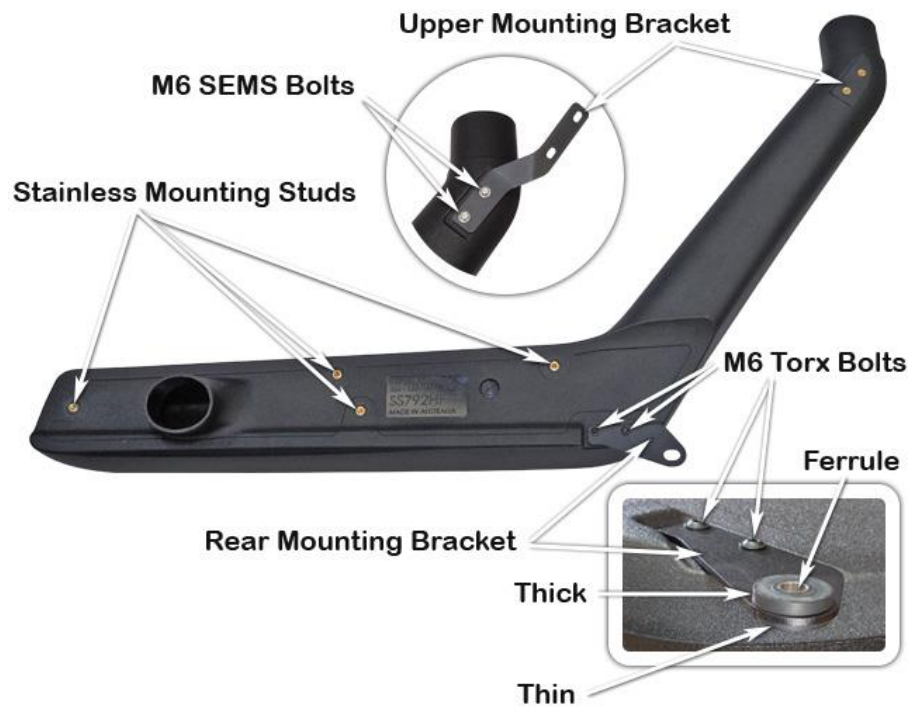

Apply Loctite 243 to the two M6 x 12mm Torx bolts (Item 7) and secure the rear mounting bracket (Item 5) to the snorkel body (Item 1) as shown.

Install the rubber grommet (Item 9) into the rear mounting bracket (Item 5) with the thicker side of the grommet facing the panel/backside side of the snorkel body.

Install the stainless-steel ferrule (Item 10) into the grommet as shown.

Carefully install the snorkel body (Item 1) to the guard panel.

When correctly aligned, fasten the snorkel body to the guard panel with the body washers (Item 12) and nyloc nuts (Item 13).



Snorkel Body

Position the rubber grommet & ferrule assembly (Item 9 & 10) central to the rear mounting bracket (Item 5) slot.

Mark the centre point of the rear mounting bracket (Item 5) through the rubber grommet & ferrule assembly (Item 9 & 10) as shown.

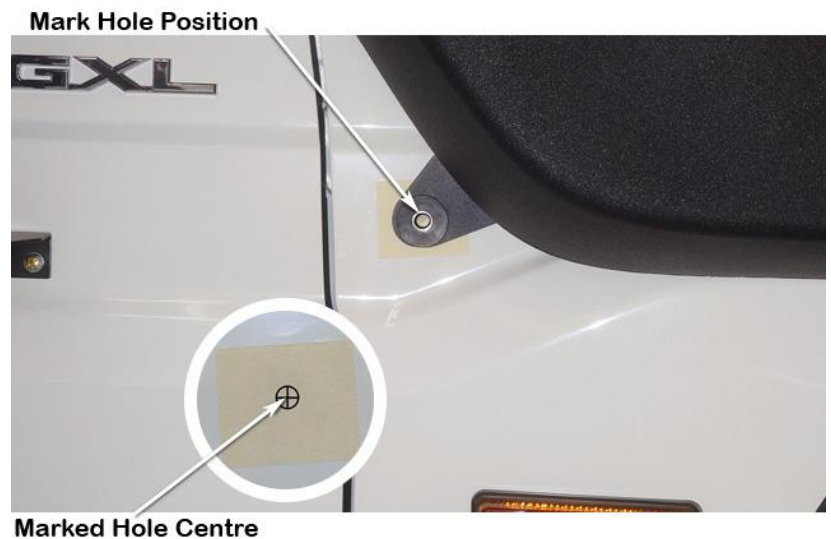

Marked Hole Centre

NEW ZEALAND INSTALLATIONS ONLY :

Safari have developed 2 methods of Snorkel A pillar attachment, for the conventional method please proceed with the current document alternatively please see the link below for further instructions.

www.safari4x4.co.nz/apillarmounting

17

Mark the centre point of the two slots in the upper mounting bracket (Item 3) onto the vehicle A 'Pillar as shown.

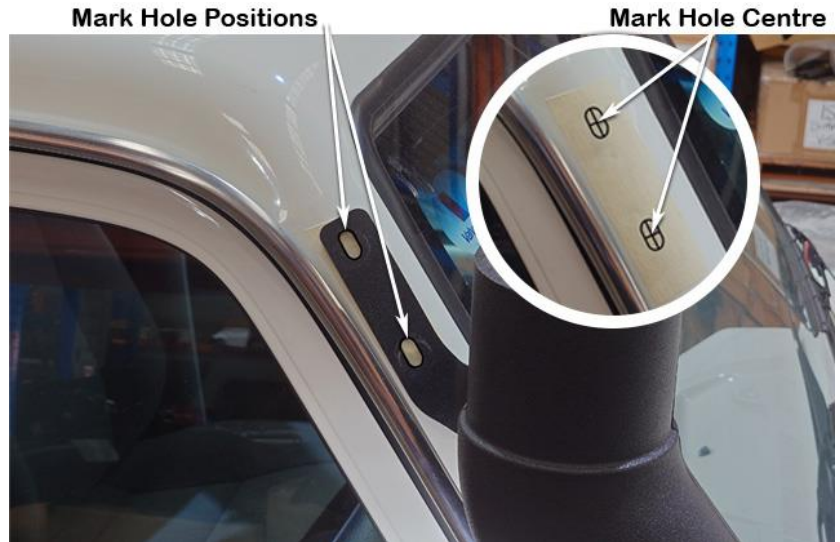

18

Remove the snorkel body (Item 1) from the vehicle along with the upper mounting bracket (Item 3) & rear mounting bracket (Item 5).

Drill a pilot hole at the center of the two marked hole positions in the A 'Pillar. Drill each hole position to 11mm diameter with a step drill or 11mm drill bit.

Deburr & paint holes to prevent rust.

Install the two M8 Rivet Nuts (Item 16) into the 11mm holes as shown.

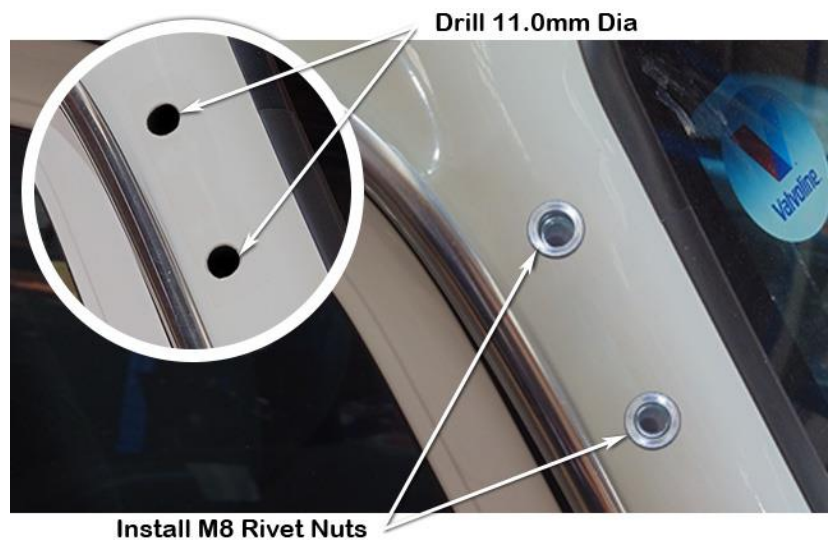

19

Drill a pilot hole at the rear mounting brackets (Item 5) lower marked hole position in the guard panel.

Drill the hole position to 9mm Dia. with a step drill or 9mm drill bit.

Deburr & paint holes to prevent rust.

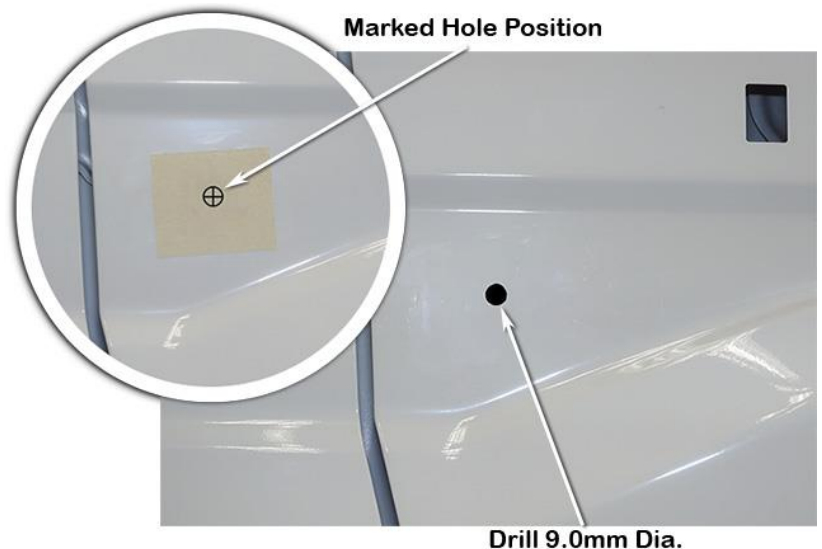

Carefully re-install the snorkel body (Item 1) to the guard panel.

When correctly aligned, fasten the snorkel body to the guard panel with the body washers (Item 12) and nyloc nuts (Item 13).

Fasten the rear mounting bracket (Item 5) using the M8 x 30mm Hex drive flange bolt (Item 15), Black Mount Spacer (Item 17), body washer & nyloc nut (Items 12 & 13).



Position the rubber bracket gasket (Item 4) between the upper mounting bracket (Item 3) and A 'Pillar panel.

Ensure gasket is aligned to the two installed Rivet Nuts (Item 16) in the A 'Pillar panel.

Secure the upper mounting bracket (Item 3) to the A 'Pillar using the two M8 x 20mm Hex drive flange bolts (Item 14).



All Vehicles:

Follow Steps 22 – 40

22

Install the ARMAX air ram assembly (Item 2) onto the snorkel body.

Align the ARMAX air ram assembly mount holes with the four pre-drilled 2mm holes in snorkel body inlet.

Secure the ARMAX Air Ram (Item 2) to the Snorkel Body (Item 1) with the four black self-tapping screws (Item 8).



23

Remove foam seal from air cleaner inlet snout.

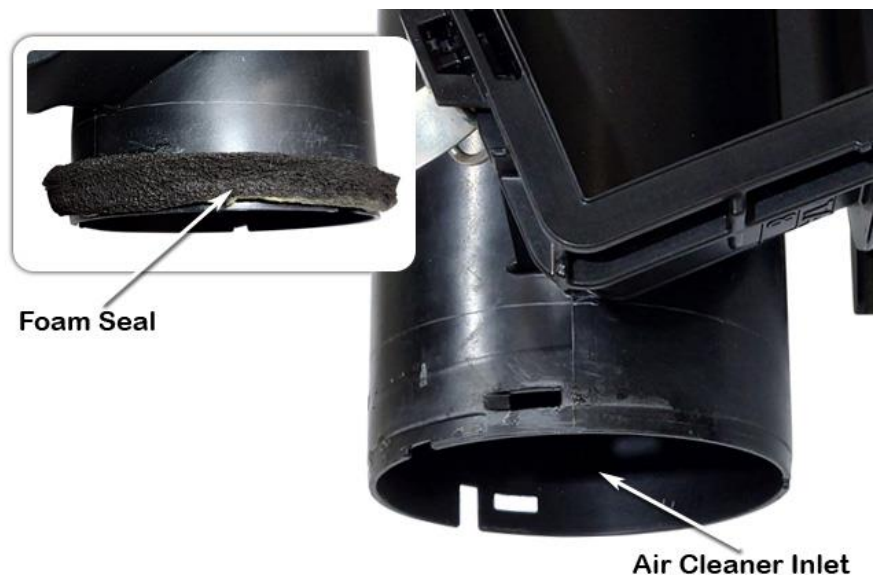

Remove & Retain the OE Captive Bolt & Washer Assy along with the Rubber Grommet from the lower air cleaner base mounting bracket.

Mark the bracket - flush with the bottom of the air cleaner base.

Using a body saw or hacksaw blade, remove the mounting bracket flush with the bottom face of the air cleaner base.



Measure 40mm from the bottom of the air cleaner base.

Mark on the rib with which the air cleaner base mounting bracket was removed - a gradual curved trim line from the bottom of the air cleaner base to the external edge of the rib.

Trim the air cleaner base rib along marked line.



Mark the air cleaner base around the edge of the standard air inlet snout where shown.

Using a body saw, cut along the marked line.

Remove & discard the standard air inlet snout.



Measure 15mm down from the lower support rib of the sealing face of the air cleaner base.

Using a sharp knife, grinder & flat file trim the 8 ribs indicated to the 15mm measurement, as shown.

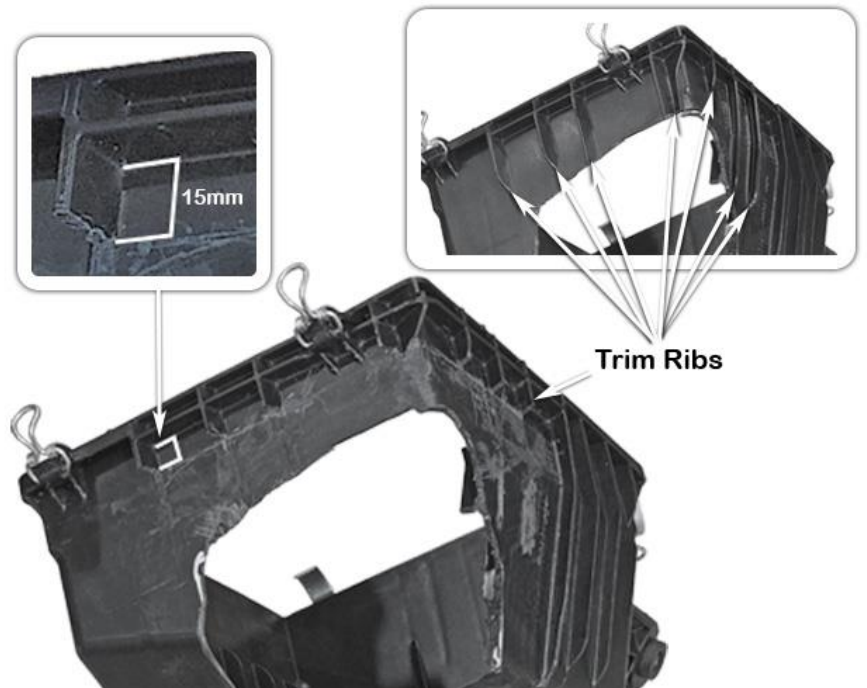

Align the Side Air Cleaner Template (Item 20) to the air cleaner base as shown.

Tape the template to the air cleaner base with masking tape.

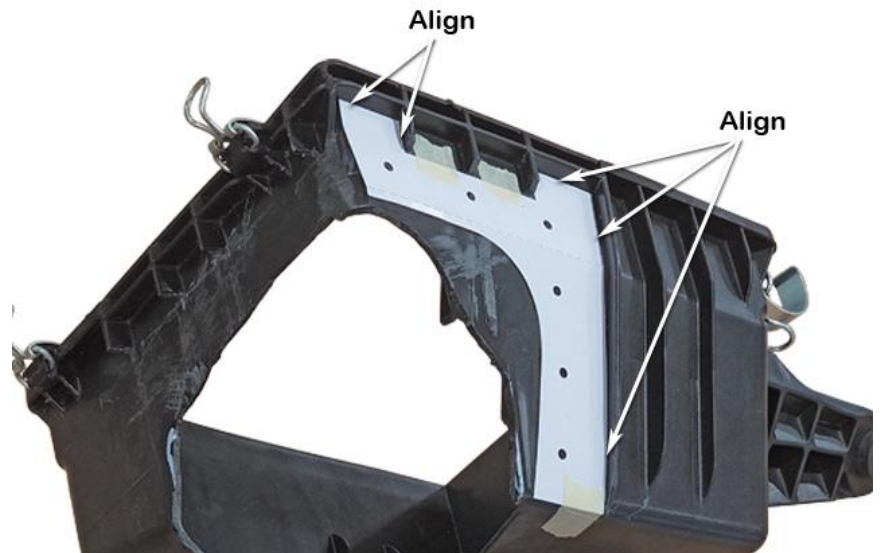

Align the Lower Air Cleaner Template (Item 21) to the air cleaner base.

Firstly, aligning the two hole positions of the Lower Template (Item 21) with the lower hole positions of the Side Air Cleaner Template (Item 20) as shown.

Secondly, align the RH finger on the Lower Template (Item 21) to the remaining ribs on the side of the air cleaner base.

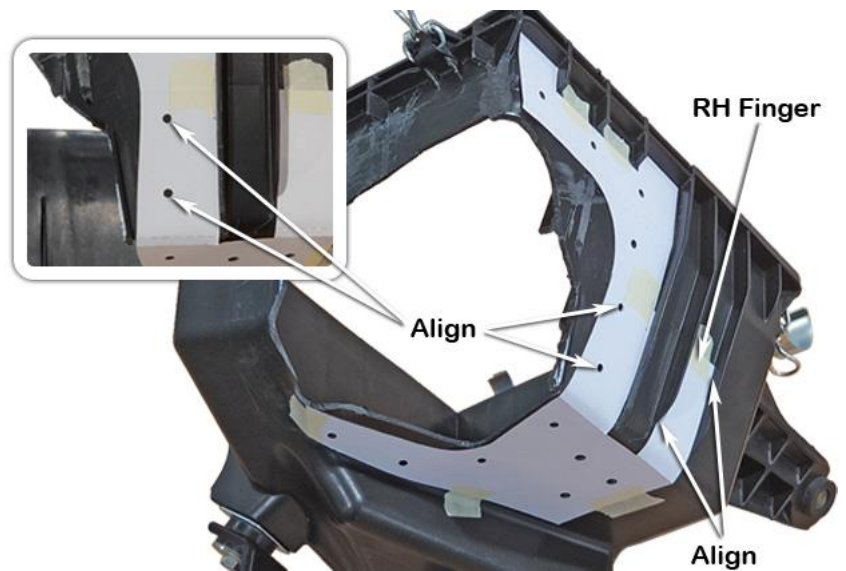

Align the Rear Air Cleaner Template (Item 19) to the air cleaner base as shown.

Ensure all templates are taped securely to the air cleaner base.



With all three templates aligned on the air cleaner base, mark all 20 hole positions and the required air cleaner base cut-out.

Remove the templates.

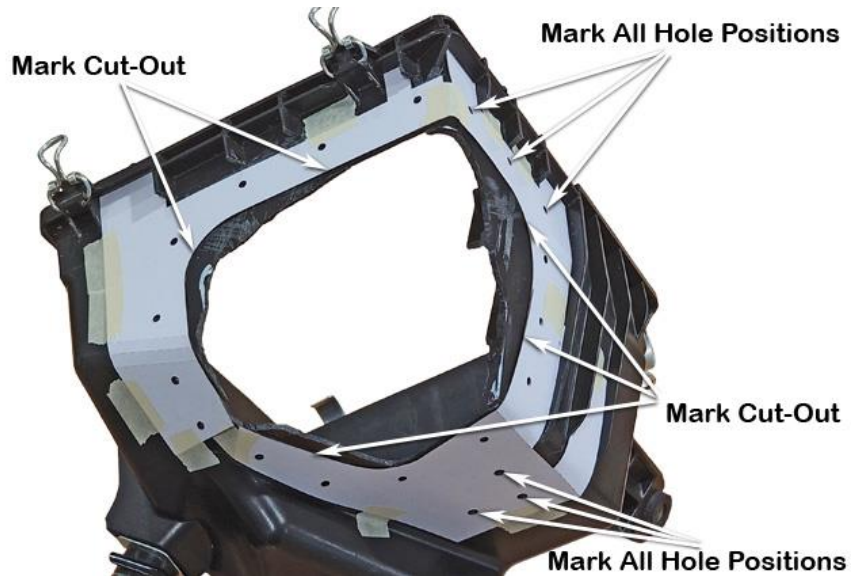

Using a 4.0mm drill bit, drill all 20 indicated marked hole positions.

Using the body saw cut the new air cleaner base inlet hole as marked in step 31.

Using the body saw remove the two internal ribs shown.

Trial fit the air entry hose (Item 18) to ensure the inlet hole is correct and all holes are aligned.

Remove the air entry hose.

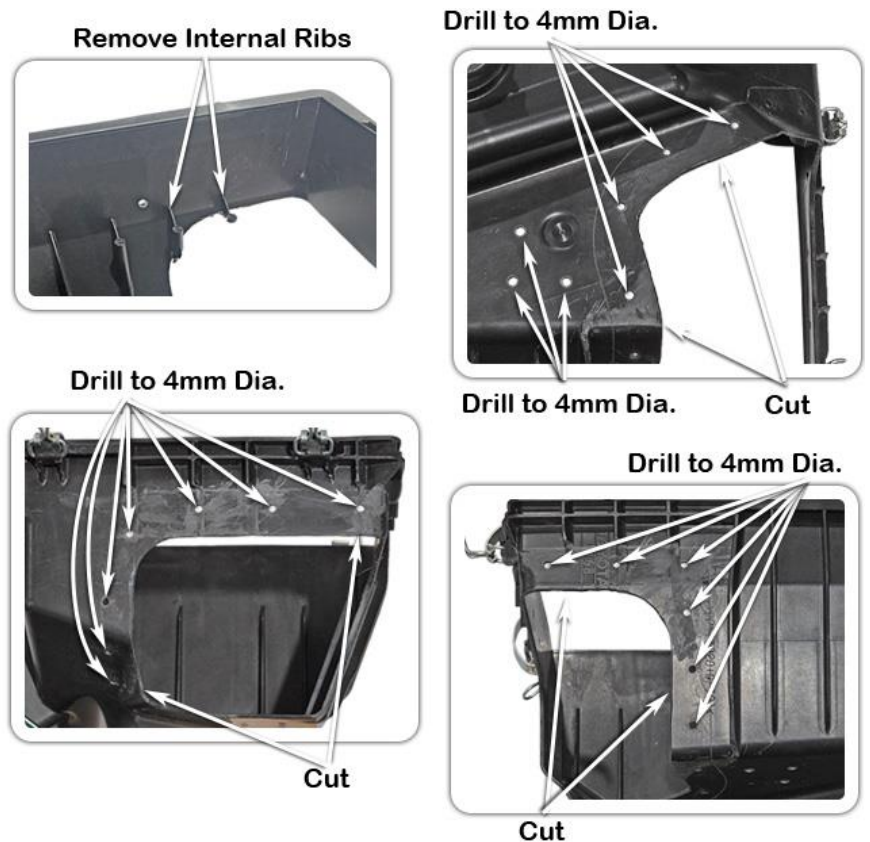

Using a 5.0mm drill bit, drill the three indicated hole positions to 5mm Dia. on the bottom of the air cleaner base.



Deburr all 20 drilled holes and the new air inlet hole

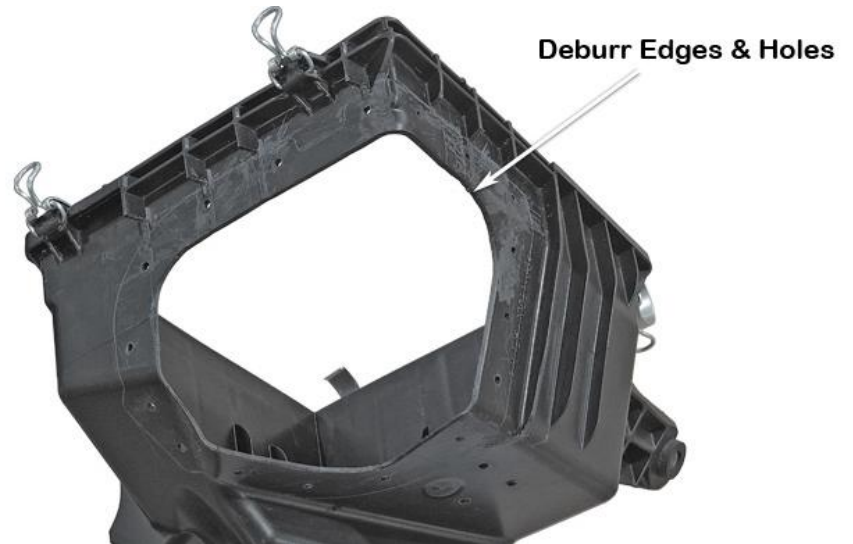

Apply specified adhesive sealant to the flange of the Air Entry Hose (Item 18), apply an additional amount of sealant to the 5 corner sections of the air entry hose flange.

Install the air entry hose (Item 18) onto the air cleaner base. Position the hose support plates (Item's 22,23,24,25 & 26) onto the air entry hose flange.

Install all 17 pop rivets (Item 27) from the inside of the air cleaner base through the air entry hose and clamping plates.

N.B: the orientation of all 17 pop rivets.

When all the pop rivets are in place and the hose aligned correctly, work from the corner of the air cleaner base outwards and fasten the pop rivets using a pop rivet gun.

Clean-up any excess sealant inside and outside to ensure a neat finish.

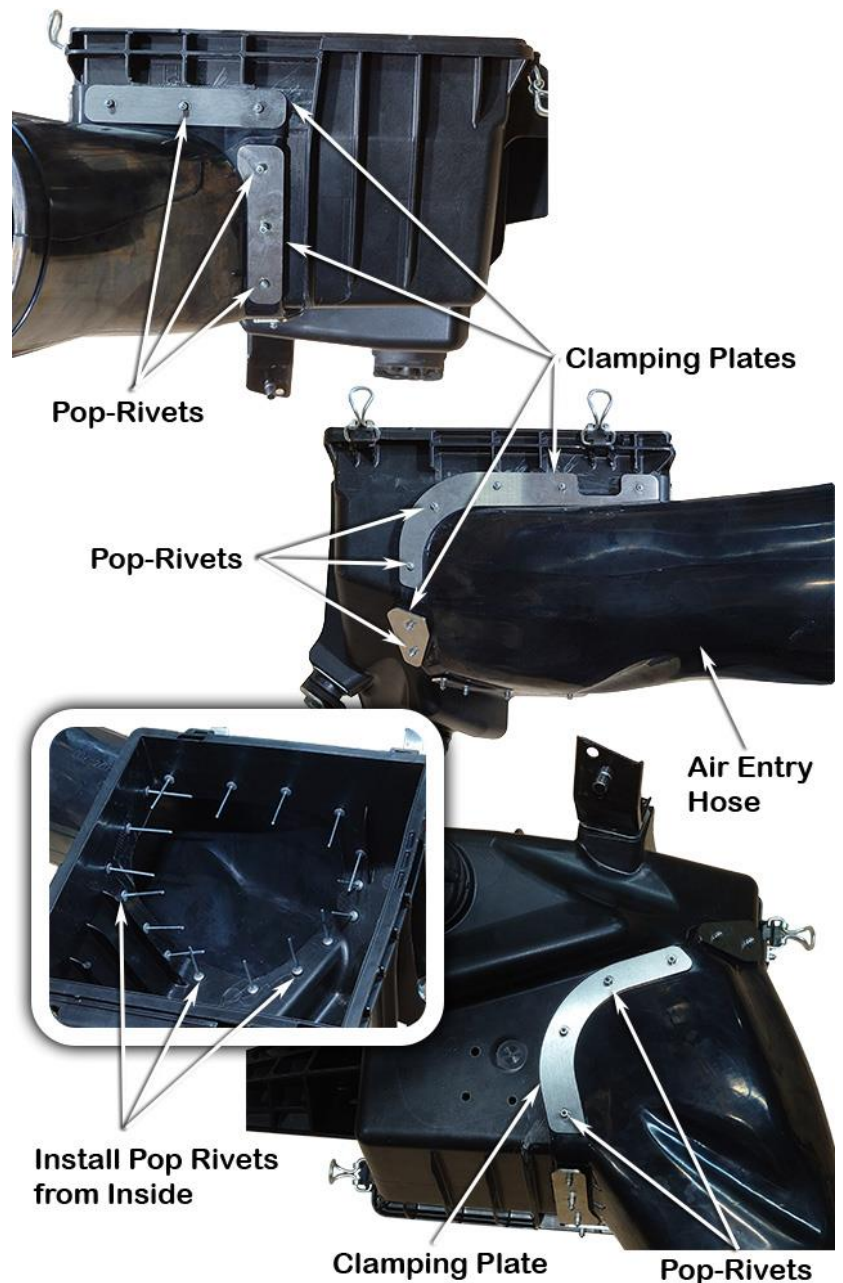

Install the OE Rubber Grommet and the Captive Bolt & Washer Assy retained from step 24 onto the Air Cleaner Mount Bracket (Item 28) as shown.

Apply specified adhesive sealant to the Air Cleaner Mounting Bracket (Item 28) as shown.

Install the Air Cleaner Mounting Bracket (Item 28) onto the bottom of the air cleaner base, aligning the three holes in the mounting bracket with the three 5mm holes in the bottom of the air cleaner base.

Secure the Air Cleaner Mounting Bracket (Item 28) to the air cleaner base with the M5 B/H Bolts, Washers & Nyloc Nuts (Item's 29, 30 & 31).

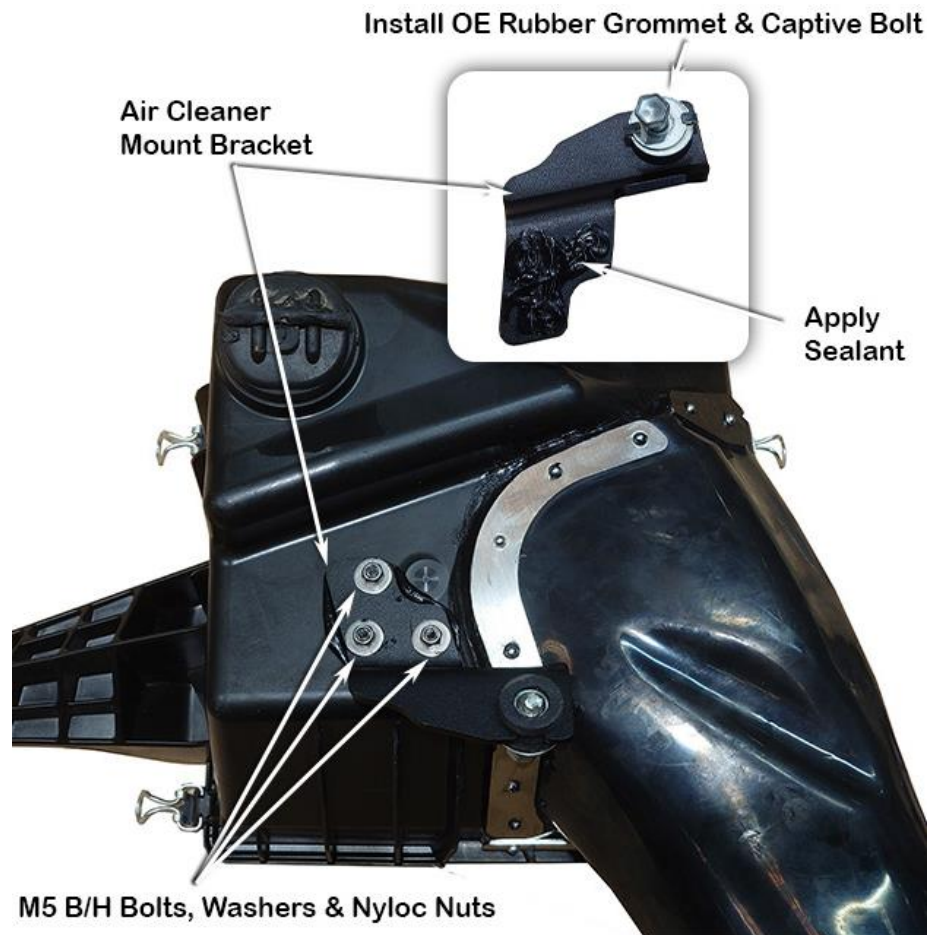

INSTALLER OPTION :

The air cleaner housing base contains a drain valve as shown. The drain valve can permit water to enter the air intake.

Safari advises that the drain valve should be sealed to ensure a watertight installation.



Loosely install the 110/130mm hose clamp (Item 32) loosely over the air entry hose (Item 18).

Note the orientation of the hose clamp.

Apply a small amount of lubricant to the inside of the air entry hose and install the air cleaner base assembly guiding the air entry hose over the snorkel body outlet snout.

Secure the air cleaner base with the original mounting hardware and tighten the 110/130mm hose clamp (Item 32).



Install the standard air filter element, air cleaner lid and any additional components that may have been removed during the snorkel installation process.

40 N.B: It is the installer's responsibility to ensure that all connections are watertight.