



SS987HPD

SAFARI ARMAX SNORKEL
 FORD RANGER P703 / EVEREST U704
 2.0L 4cyl Bi-Turbo & 3.0L V6 Turbo Diesel Engines
 N.B: Compatible with Ford OE & EGR Fender Flares
 N.B: Not compatible with some manufacturers side rails



17/04/2024

Parts List

ITEM	PART NO.	DESCRIPTION	QTY
1	682-133-600	BODY - SNORKEL (SS987HP)	1
2	000-135-980	ARMAX AIR RAM ASSEMBLY	1
3	682-032-600	BRACKET - UPPER MOUNTING	1
4	000-002-100	BOLT - HEX - 6mm x 1.0 x 14mm (SEMS)	2
5	000-958-625	POP RIVET - 4.8mm x 10mm (Black Anodised)	3
6	682-435-600	GASKET - UPPER MOUNTING BRACKET (Nylon)	1
7	000-110	STUD - 8mm x 1.25 x 25mm - S/S	6
8	000-311-300	WASHER - BODY - 8mm x 30mm - S/S	6
9	000-205-300	NUT - NYLOC - 8mm x 1.25mm - S/S	6
10	682-024-600	HOSE - AIR ENTRY	1
11	682-025-600	PLATE - HOSE SUPPORT - S/S (Side Upper)	1
12	682-025-625	PLATE - HOSE SUPPORT - S/S (Front Upper)	1
13	682-025-650	PLATE - HOSE SUPPORT - S/S (Front Lower)	1
14	682-025-675	PLATE - HOSE SUPPORT - S/S (Lower Small)	1
15	682-025-700	PLATE - HOSE SUPPORT - S/S (Lower Large)	1
16	682-025-725	PLATE - HOSE SUPPORT - S/S (Side Rear)	1

17	000-958-175	POP RIVET - 4.0mm x 17mm	14
18	000-093-400	BOLT - B/H CAP SCREW - 4.0mm x 0.7 x 16mm - S/S	3
19	000-300-350	WASHER - BODY - 4.0mm x 12mm - S/S	4
20	000-223-300	NUT - NYLOC - 4.0mm x 0.7mm - S/S	3
21	682-959-000	PLUG - AIR INLET BLANK-OFF	1
22	000-1913	CLAMP - HOSE - 120/140mm - S/S	1
23	000-951-480	SCREW - S/T - 4.2mm x 13mm - (Black)	4
24	000-987-365	CABLE TIE - 7.8mm x 365mm	1
25	000-987-178	CABLE TIE - 4.8mm x 178mm	4
26	682-217-600	TEMPLATE - AIR CLEANER - (Side Upper)	1
27	682-217-625	TEMPLATE - AIR CLEANER - (Front Upper)	1
28	682-217-650	TEMPLATE - AIR CLEANER - (Front Lower)	1
29	682-217-675	TEMPLATE - AIR CLEANER - (Lower)	1
30	682-217-700	TEMPLATE - AIR CLEANER - (Lower)	1
31	682-016-600	RUBBER - FENDER INFILL	1
32	682-017-600	TEMPLATE - FENDER	1



SS987HPD

SAFARI ARMAX SNORKEL
FORD RANGER P703 / EVEREST U704
2.0L 4cyl Bi-Turbo & 3.0L V6 Turbo Diesel Engines
N.B: Compatible with Ford OE & EGR Fender Flares
N.B: Not compatible with some manufacturers side rails

Installation Guide

Fitment to:

- Right Hand Side

Fitting Time:

- 270min

Special Tools:

- Body Saw (Reciprocating)
- Pop Rivet gun (Swivel Head)
- Step Drill and Metric Drill Bits
- Sikaflex 227 Adhesive Sealant
- Allen Key Set (Metric)
- Die Grinder
- Files
- Masking Tape
- Loctite 243 (thread lock)
- Touch-up paint

Prior to commencing the installation, it is the installer's responsibility to verify that all components and particularly the fender template (Item 32) are correct.

Attention Installer:

Prior to commencing the installation of the SS987HPD Safari ARMAX Snorkel, please discuss the following with the customer.

N.B: Due to the high performance characteristics of the SS987HPD Safari ARMAX Snorkel, increased induction levels may be heard at low RPM.

1 Remove the following in accordance with the factory service manual:

- Air Cleaner Assembly
- RH Mud Flap
- RH Inner Guard Liner (Main Splash Guard Section)
- RH Front Wheel Arch Moulding
- RH Inner Guard Liner (Secondary Splash Guard Section)

Hint: Cover the air intake duct with a plastic bag or rag to prevent any foreign matter from entering the engines air intake and potentially causing turbocharger / engine damage.

Caution: Extreme care must be taken when removing the Front Wheel Arch Moulding, the wheel arch moulding clip mounts are very easily broken off.

Hint: To release the plastic clips use a 7mm / 8mm ¼" drive socket and extension bar.

Optional: Remove the RH wheel arch moulding & RH Inner Guard Liner after the front fender snorkel hole modifications are complete. – See step 5

2

Remove and discard the two perforated sections from the fender template (item 32) as shown.

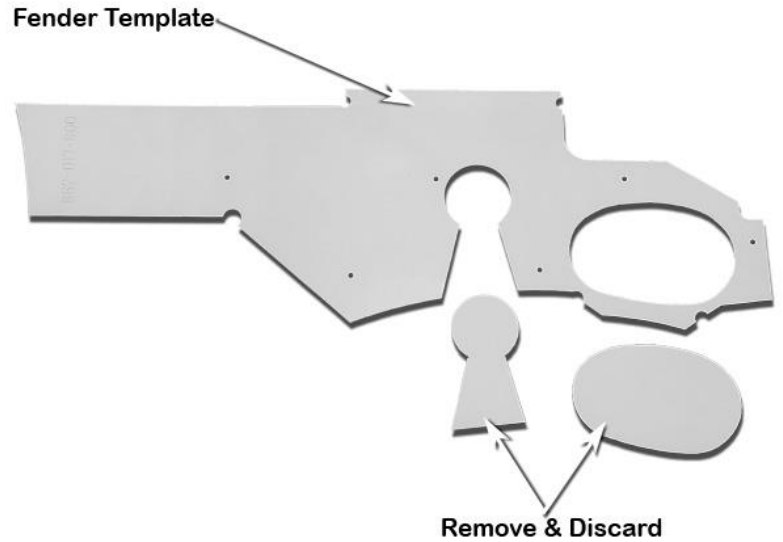

3

Align the fender template (Item 32) with the upper and rear edges of the right hand fender as shown.

Tape the template to the fender with masking tape, the template **must** follow the profile of the fender panel whilst being taped.

Mark all hole positions and the cut-out section with a felt tip pen.

Remove the fender template.

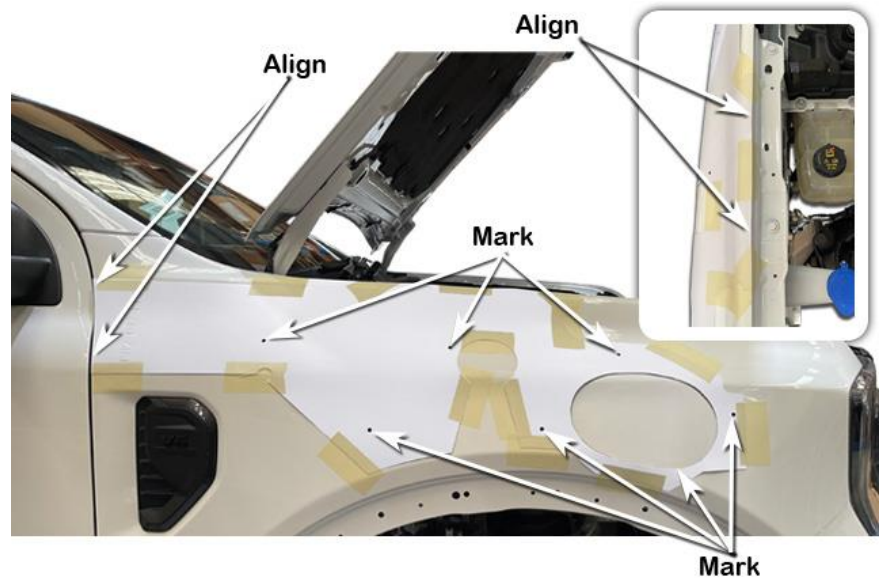

Drill a pilot hole for each of the marked hole positions.

Use a step drill to drill the six mounting holes to 16mm diameter.

Drill 1 or 2, 10mm diameter holes in the cut-out section for a start/stop point for the body saw. Using the body saw, cut the main hole in the fender as marked from the template cut-out in step 3, cutting on the outside of the marked cut line.

Thoroughly deburr and paint all holes and cut section of fender to prevent rust.

Caution: The drill bit length is extremely critical when drilling the pilot holes and 16mm diameter holes in the fender. The washer bottle assembly is mounted directly behind the area of the holes. **Do Not** use long drill bits.

Hint: Tape over the Fender vent and any other parts where metal swarf / filings can be trapped.

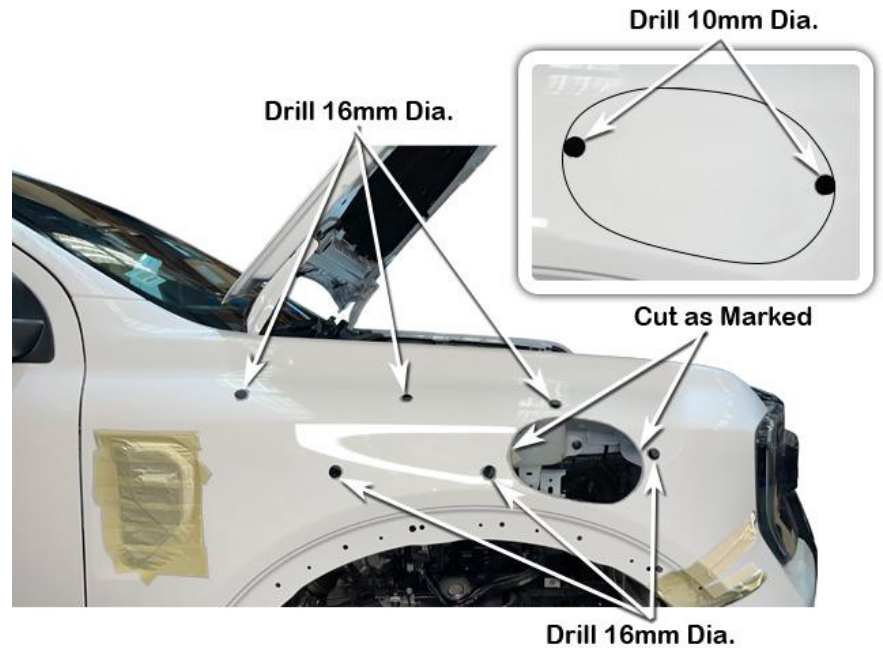

OPTIONAL: Remove the following in accordance with the factory service manual:

- RH Front Wheel Arch Moulding
- RH Inner Guard (Secondary Splash Guard Section)

Note/Caution: Extreme care must be taken when removing the Front Wheel Arch Moulding. Reach through the main hole in the fender and unclip as many of the plastic clips retaining the wheel arch moulding to the fender as possible, then carefully unclip the remaining plastic clips.

NEW ZEALAND INSTALLATIONS ONLY :

Safari have developed 2 methods of Snorkel A pillar attachment, for the conventional method please proceed with the current document alternatively please see the link below for further instructions.

www.safari4x4.co.nz/apillarmounting

6

Install the upper mounting bracket (Item 3) to the snorkel body (Item 1) with hex bolts (Item 4).

Apply Loctite 243 to each of the stainless steel mounting studs (Item 7) and install the studs finger tight into the snorkel body (Item 1) mounting inserts as shown.

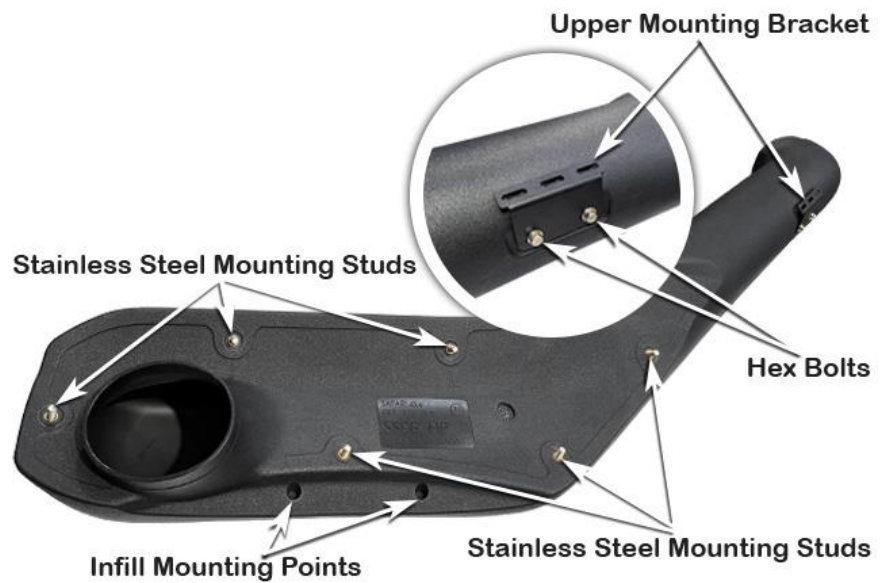

Locate the four dimples around the inlet of the Snorkel body.

Drill a 2.0mm pilot hole at each of the four dimple locations as shown.

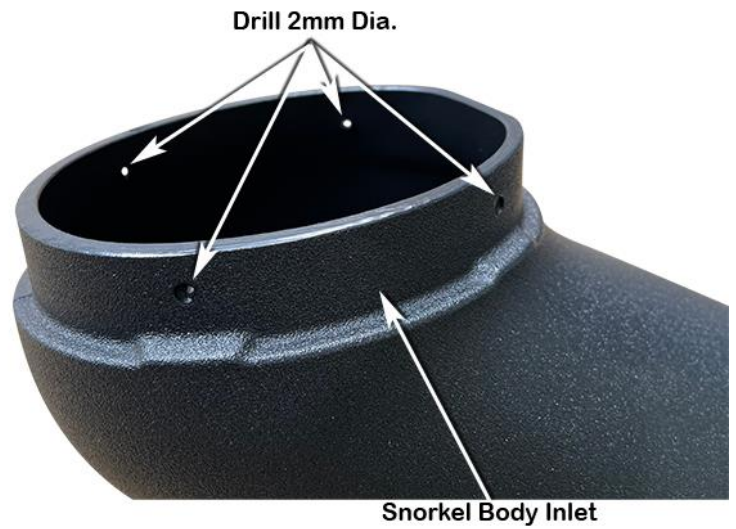

Apply Sikaflex adhesive sealant to the lower section of the snorkel body as shown.

Install the fender infill rubber (item 31) to the snorkel body (item 1), tape the infill rubber to the snorkel body in several positions to hold the infill rubber in position while the adhesive sealant cures.

Clean-up any excess sealant to ensure a neat finish.

Note: Do not install the fender infill rubber (item 31) if the vehicle is fitted with Ford OE or EGR Fender Flares.

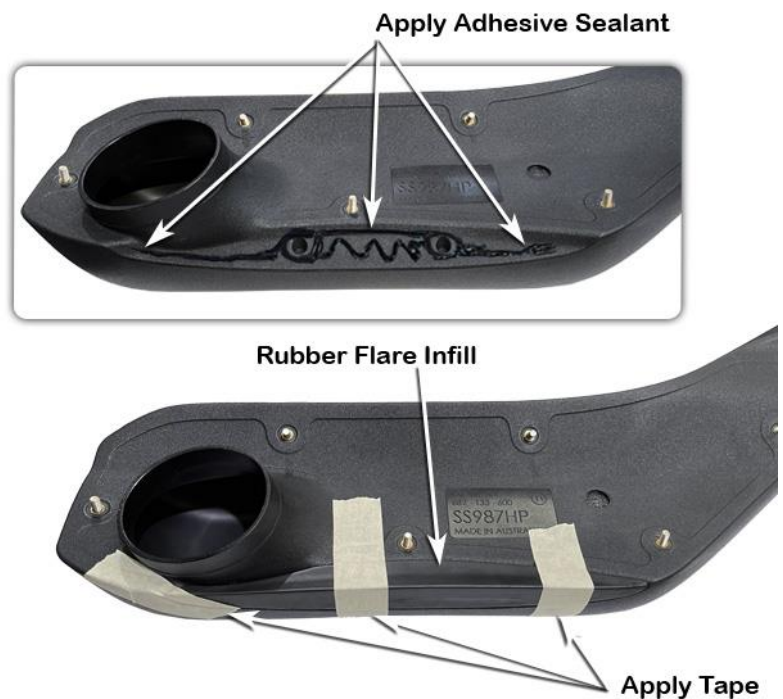

Place a strip of masking tape along the A-pillar panel.

Carefully install the snorkel body (Item 1) to the fender.

With the snorkel body correctly positioned, mark the outline of the upper mounting bracket (Item 3) onto the masking tape.

The distance from the marked line to front door edge should be approximately 10.0 - 12.0mm as shown.

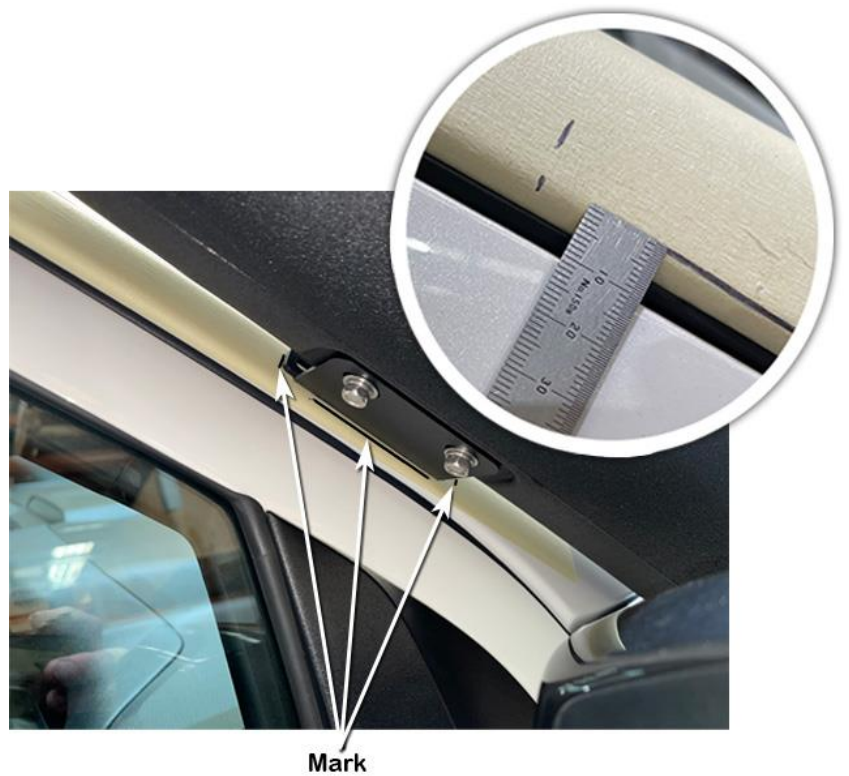

Remove the snorkel body (Item 1) from the vehicle and remove the upper mounting bracket (Item 3) from the snorkel body.

Position the upper mounting bracket (Item 3) onto the A-pillar and align the bracket with the marked bracket outline.

Mark the three mounting slot positions with a felt tip pen.

N.B: The upper mounting bracket has 3 large mounting slots to allow for bracket adjustment when upgrading from a V-spec snorkel to an Armax Snorkel.

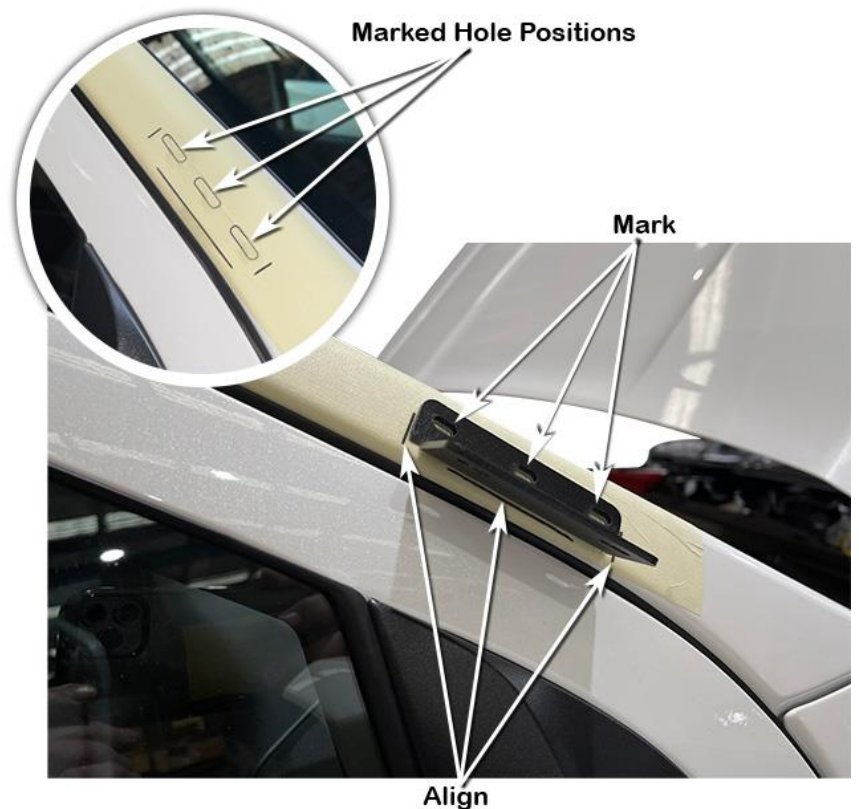

Drill a pilot hole at each of the three marked hole positions.

Drill each hole position to 5.0mm diameter with a 5.0mm drill bit.

Remove the masking tape.

Deburr and paint holes to prevent rust.

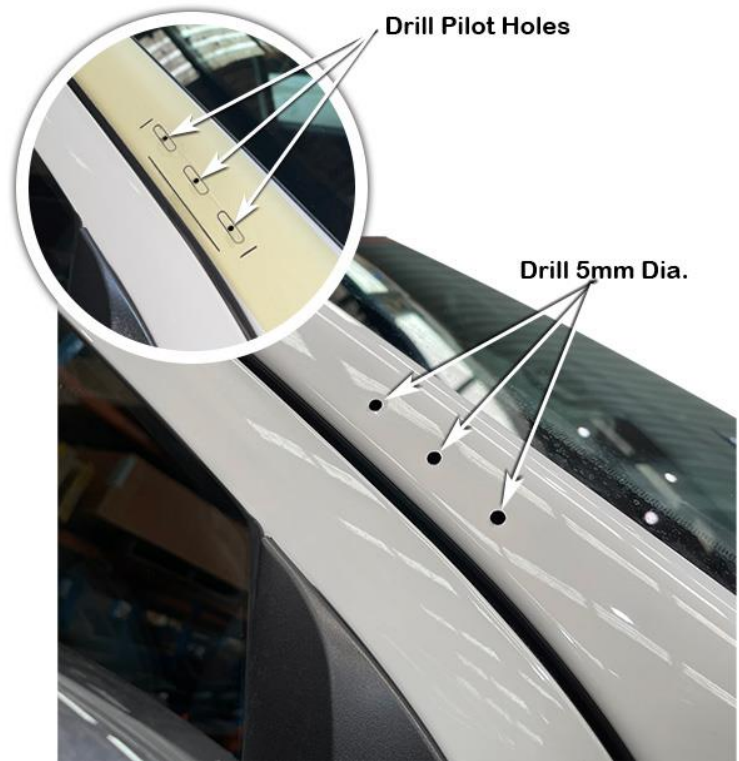

Install the nylon bracket gasket (item 6) to the upper mounting bracket (item 3) and install the upper mounting bracket and nylon bracket gasket onto the A-pillar.

Install the three pop rivets (item 5) through the bracket and gasket and into the three 5.0mm diameter holes in the A-pillar panel.

Hint: Apply two small drops of superglue to the upper mounting bracket and stick the nyloc bracket gasket to the upper mounting bracket.

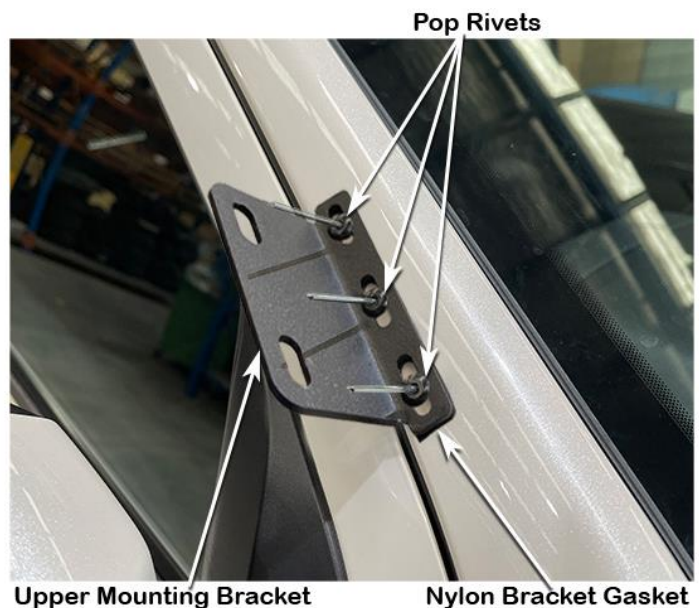

13

Using a pop rivet gun, secure the three pop rivets attaching the upper mounting bracket and nylon bracket gasket to the A-pillar panel.

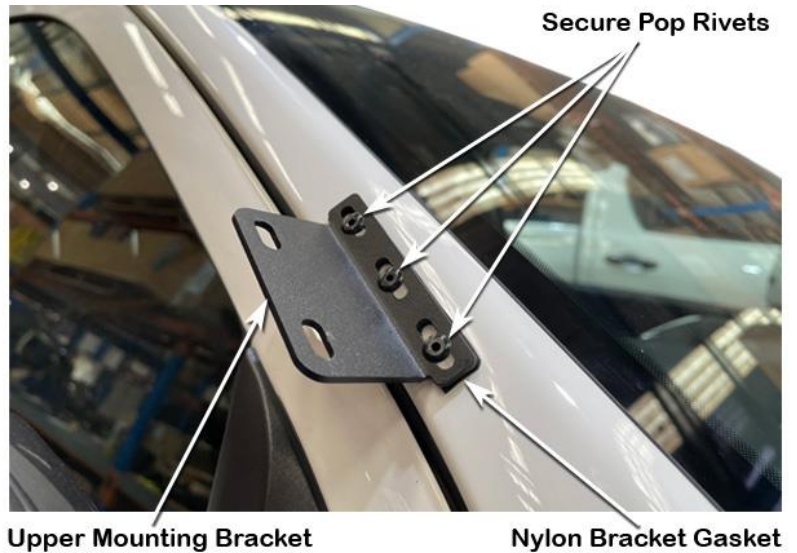

14

Unclip the washer motor loom and washer hose from the washer bottle bracket.

The unused front washer bottle bracket (shown) must be removed. Mark a cut line and using the body saw, cut the bracket off the front of the washer bottle as close as possible to the washer bottle for maximum clearance to the air entry hose when installed, Use a die grinder to neaten the cut.

N.B: Care must be taken when cutting off the unused bracket, not to cut into the washer bottle reservoir.

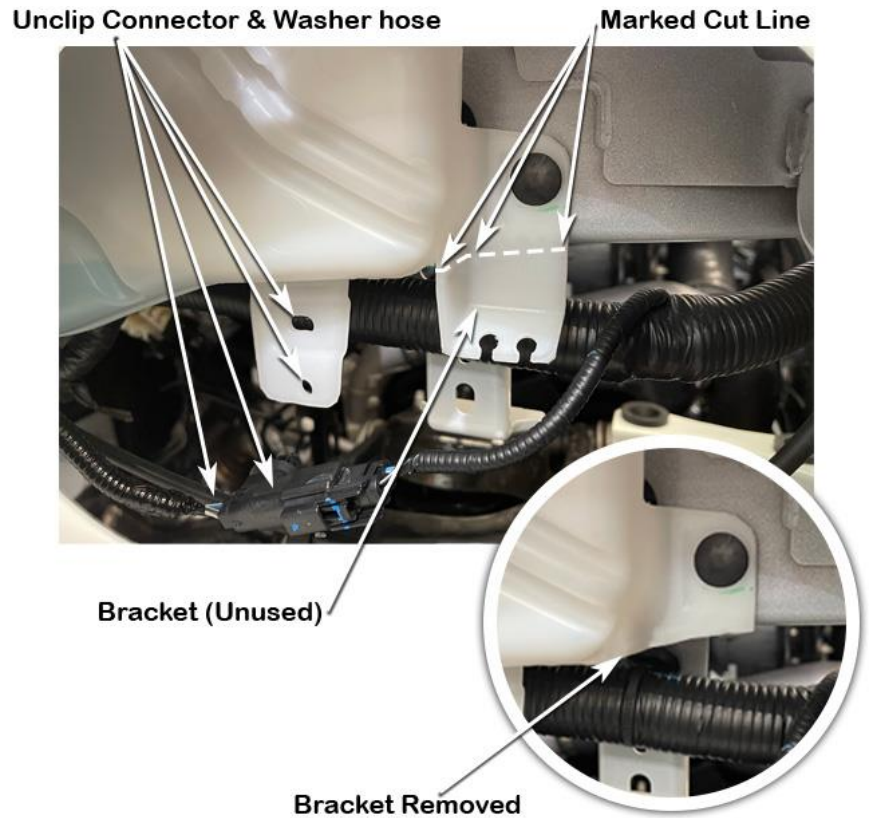

Remove and discard the mounting clip from the washer motor wiring loom connector plug.

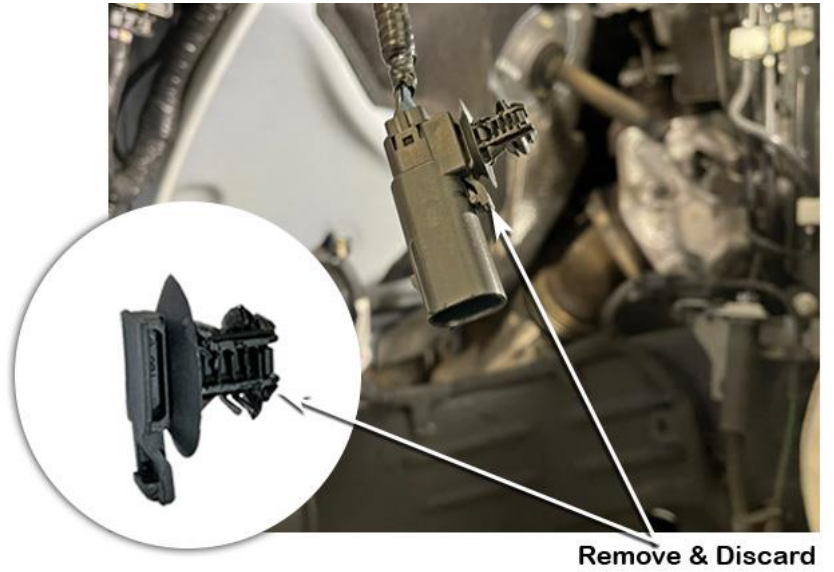

Cable tie the main loom to the vehicle's top structure rail using the large cable tie (item 24) as shown.

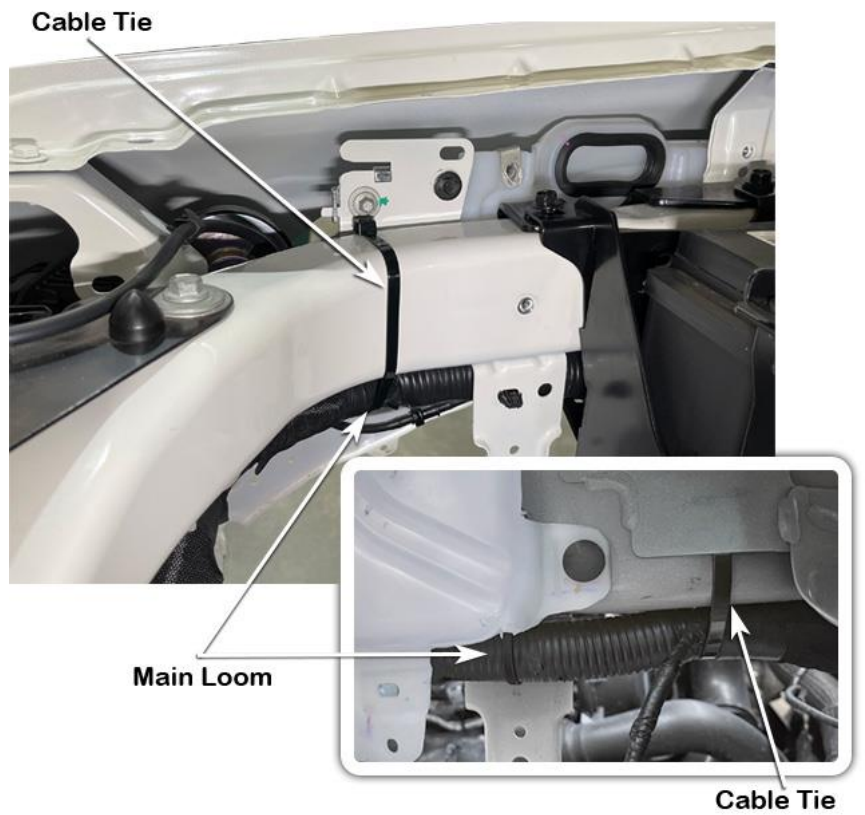

Vehicle Models with No Factory Front Camera Fitted in the Grille:

Skip steps 17 & 18

17

Vehicles with Front Camera Washer only:

Measure and mark a hole position approximately 15mm forward of the slot shown.

Drill a pilot hole at the marked hole position. Drill the hole to 6.5mm using a 6.5mm drill bit.

Deburr and paint hole to prevent rust.

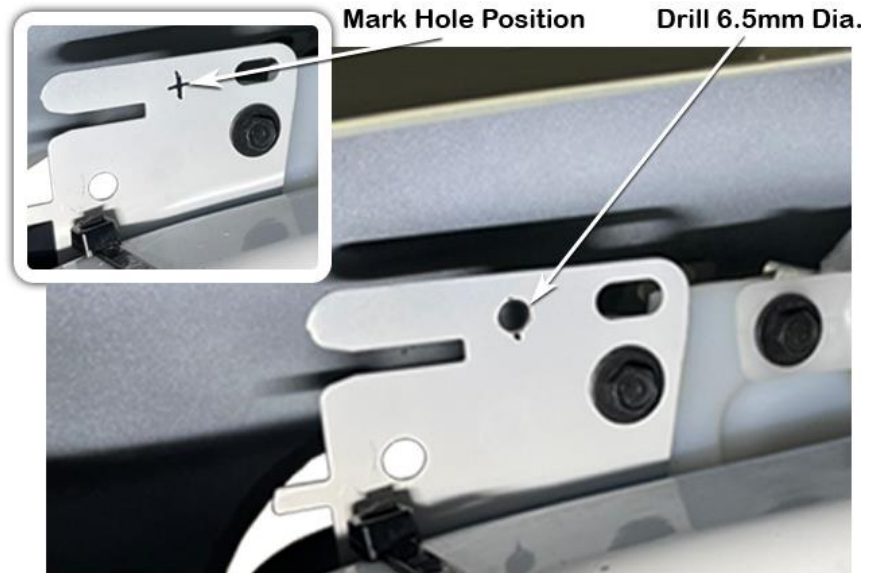

18

Vehicles with Front Camera Washer only:

Remove and reposition the washer hose mounting clip to the new mounting hole location and secure as shown. Place a piece of tape to hold the washer hose to the side of the washer bottle as shown.



Re-connect the washer motor wiring connector plugs and re-route the washer motor wiring harness along the main wiring harness, securing the washer motor wiring harness with cable ties (item 25) along the main wiring harness as shown.

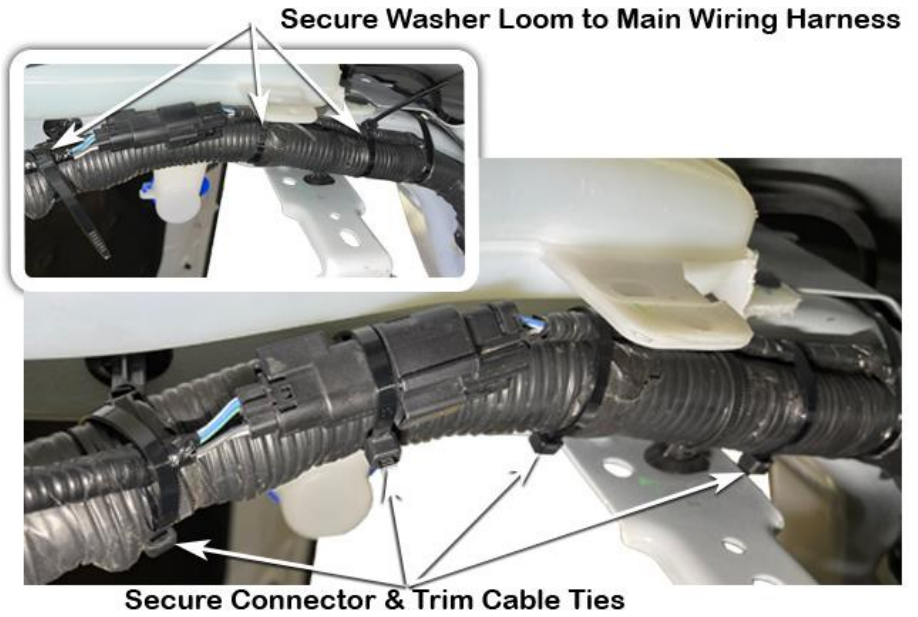

Remove and discard the standard air cleaner Inlet duct from air cleaner base.



Using the body saw and die grinder, neatly remove the two air deflector ribs from inside the air cleaner base as shown.

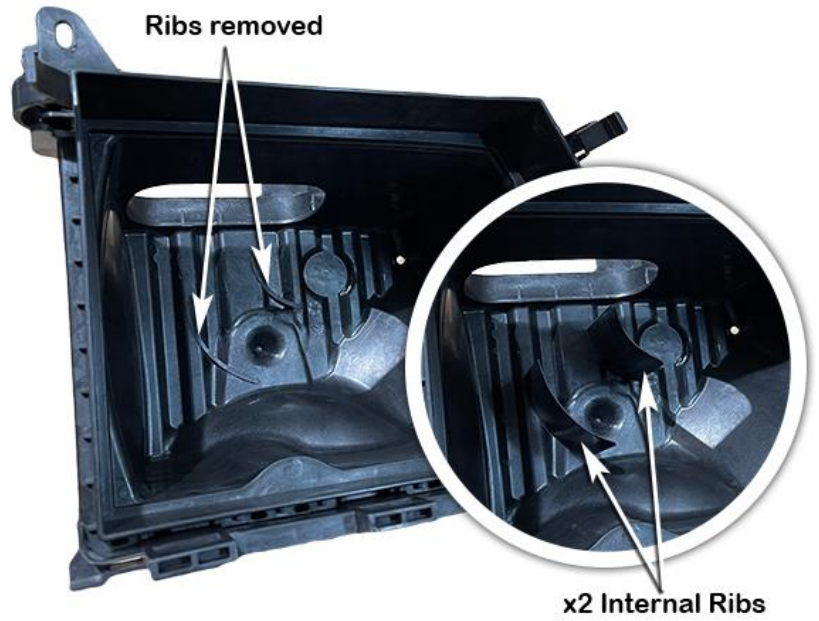

Drill a 10mm pilot hole through the air cleaner base below the 96mm diameter spigot on the side of the air cleaner base as shown.

Using the body saw, cut around the 96mm diameter spigot and remove.

Note: Cut as close to the 96mm diameter spigot, especially around the top section.

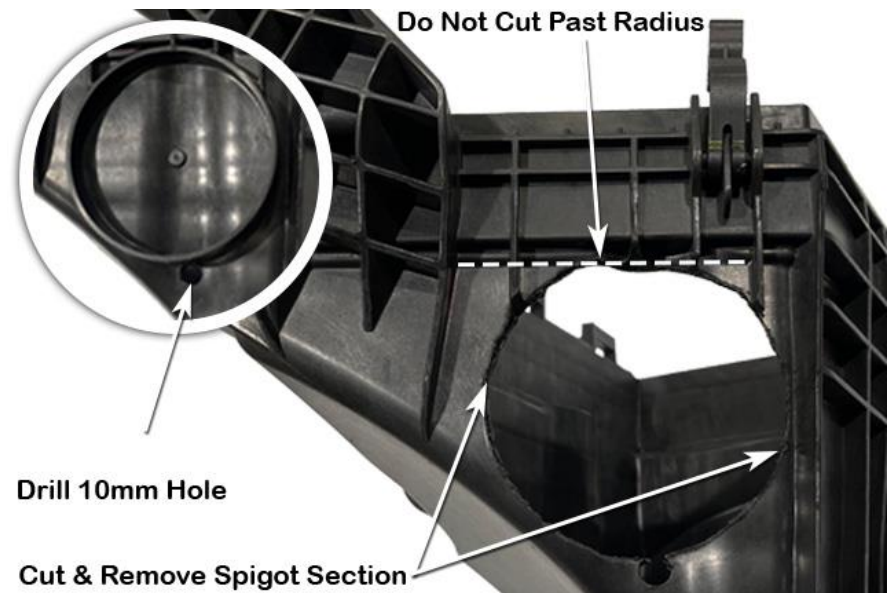

Using a paint pen marker, mark the front and side ribs on the air cleaner base as shown.

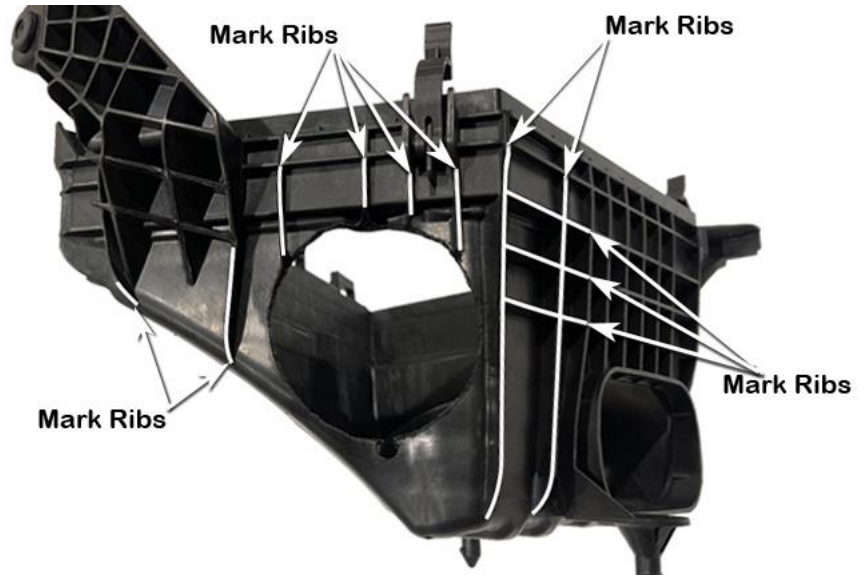

Using a body saw, hacksaw blade, chisel and die grinder, neatly remove the highlighted ribs from the front of the air cleaner base as shown.

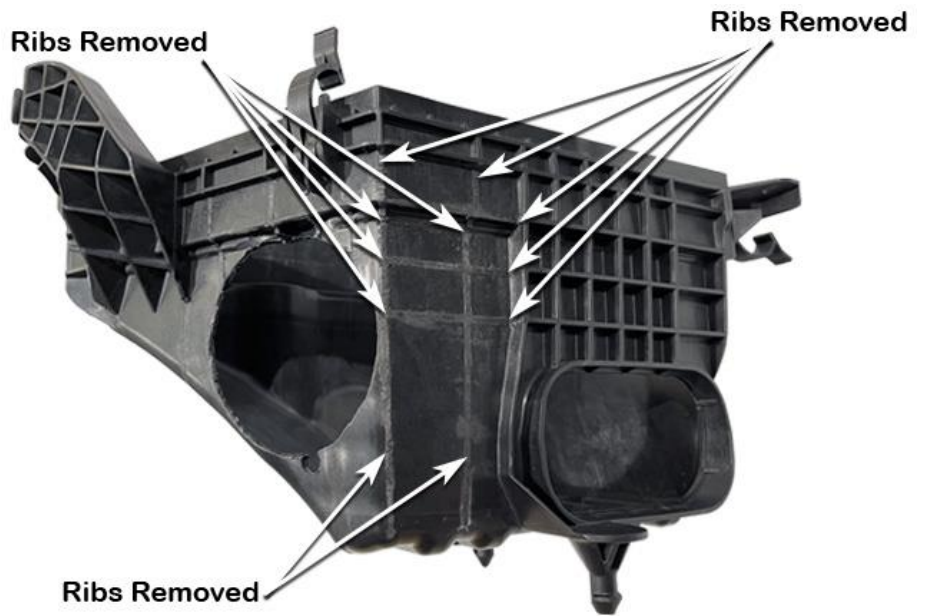

Using a body saw, hacksaw blade, chisel and die grinder, neatly remove the highlighted ribs from the side of the air cleaner base as shown.

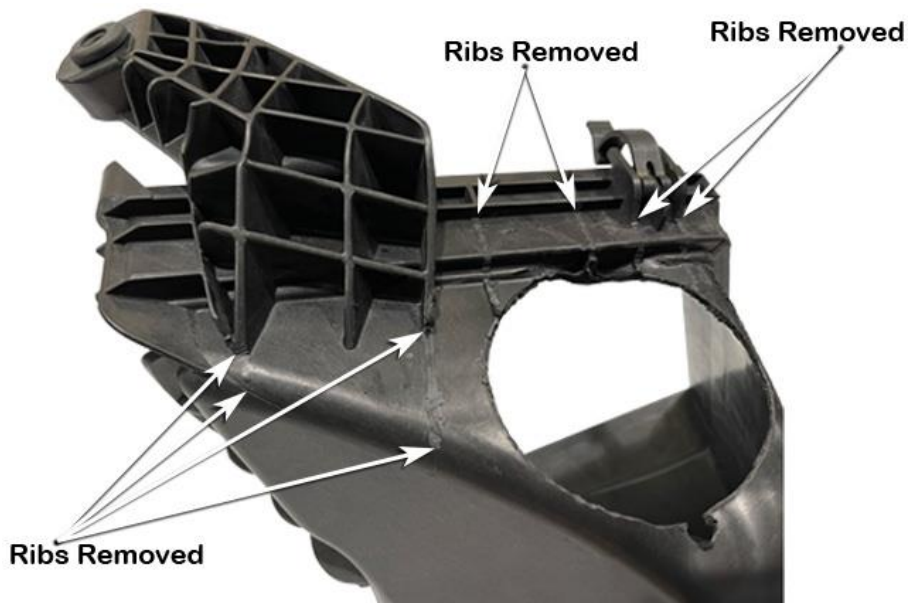

Using a paint pen marker, mark the ribs of the air cleaner base mounting bracket as shown.

Using a body saw, hacksaw blade, chisel and die grinder, neatly remove the highlighted mounting bracket ribs from the side of the air cleaner base as shown.

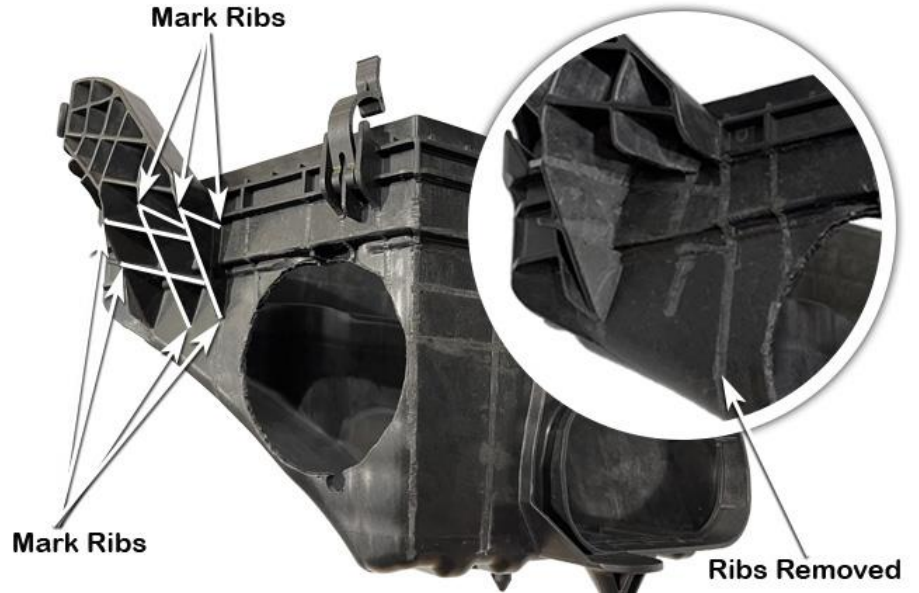

Neatly apply masking tape to the front, side and lower section of the air cleaner base as shown.

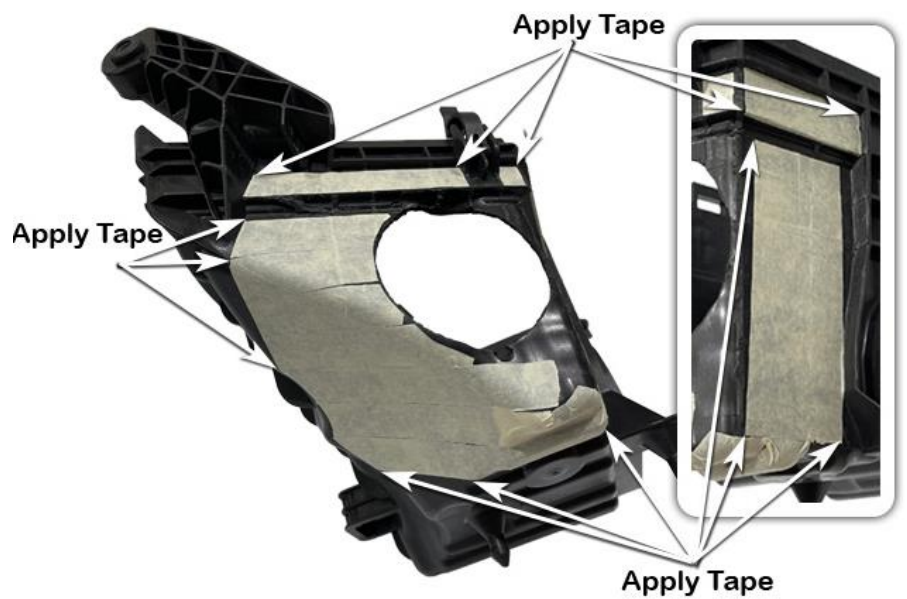

Align the front upper template (item 27) to the upper and side rib as shown. Tape in position and mark the two hole positions.

Remove the template.

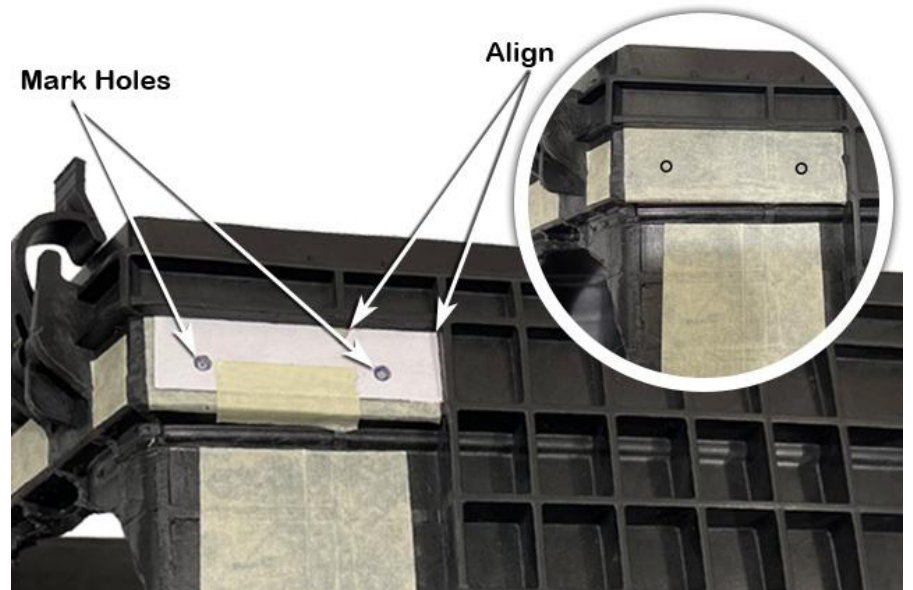

Align the front lower template (item 28) to the side ribs, angled rib and under the upper radius as shown. Tape in position and mark the four hole positions and the cut line.

Remove the template.

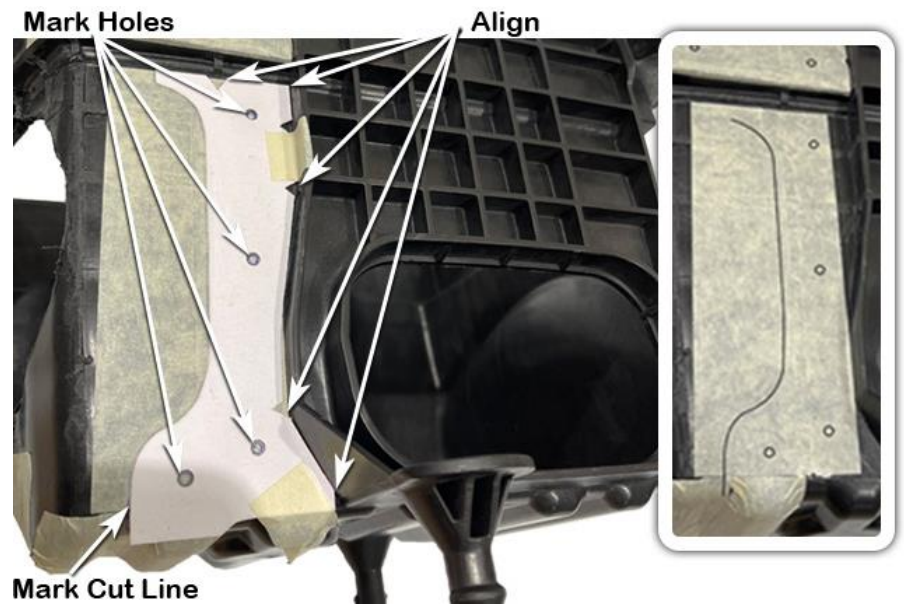

Align the side upper template (item 26) around the air cleaner clip housing and the upper rib as shown. Tape in position and mark the four hole positions.

Remove the template.

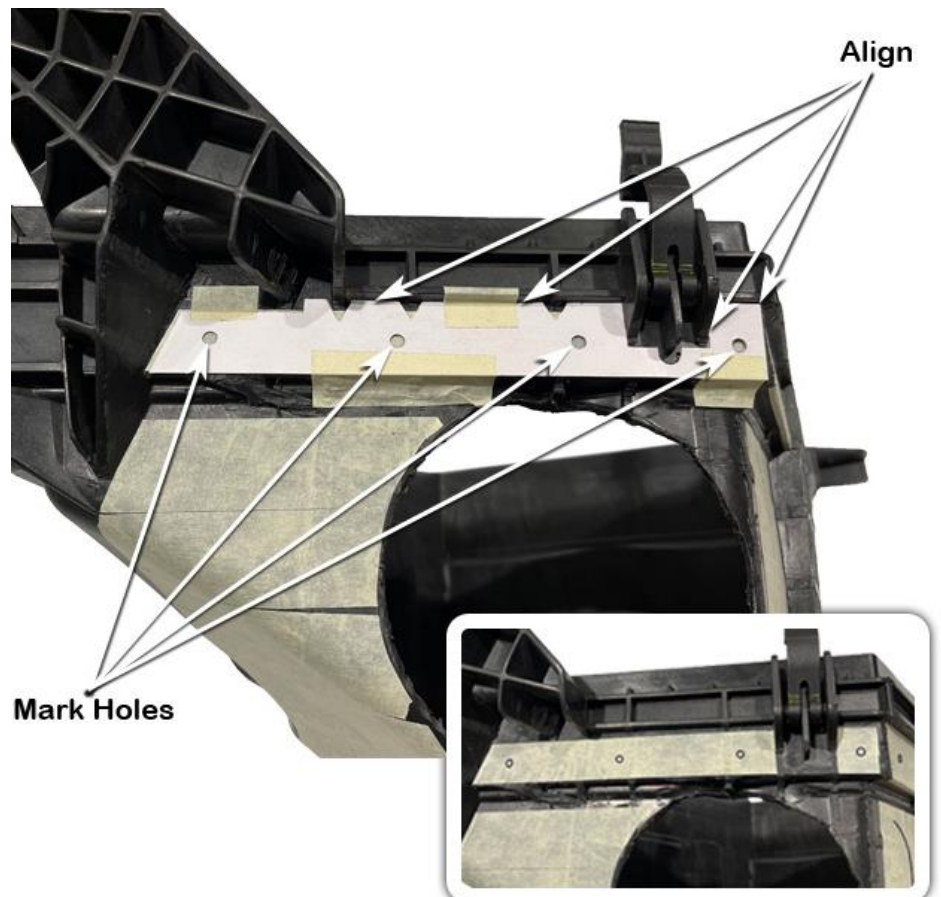

Align the side lower template (item 29) between the 2nd and 3rd ribs of the rear of the air cleaner base and to the side of the angled mounting bracket rib and under the upper radius as shown. Tape in position and mark the five hole positions and the cut line.

Remove the template.

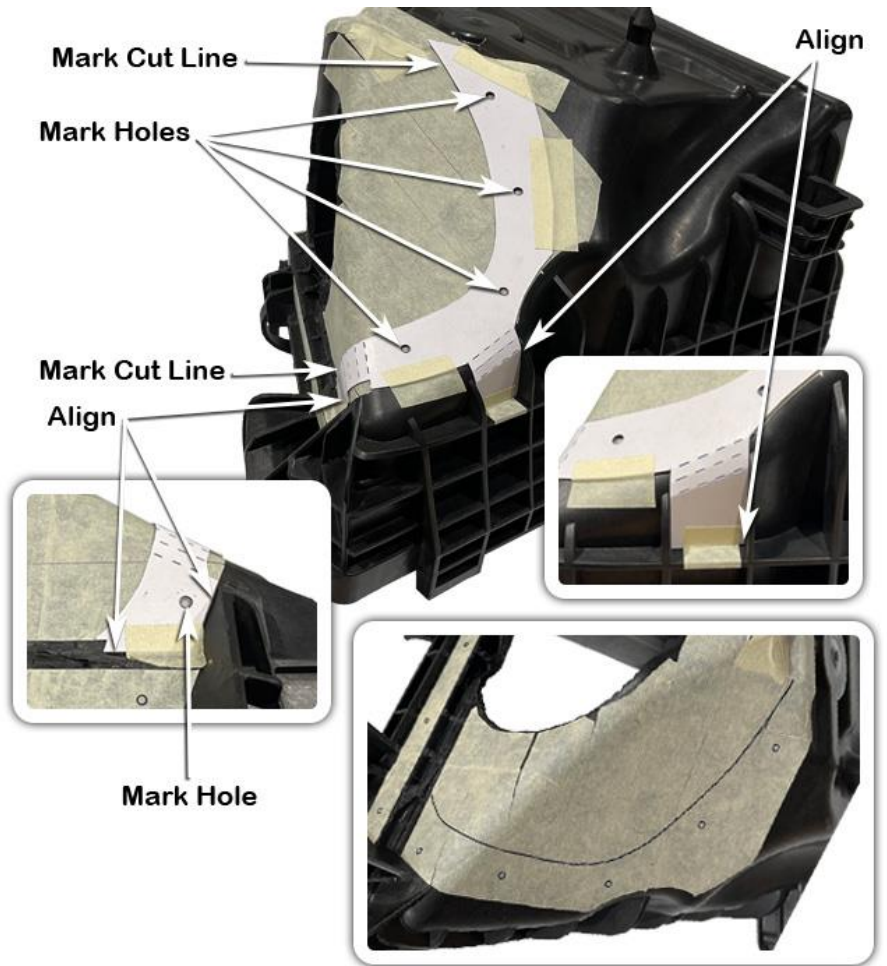

Align the lower template (item 30) over the two air cleaner base mounting pins. Tape in position and mark the two hole positions and the cut line.

Remove the template.

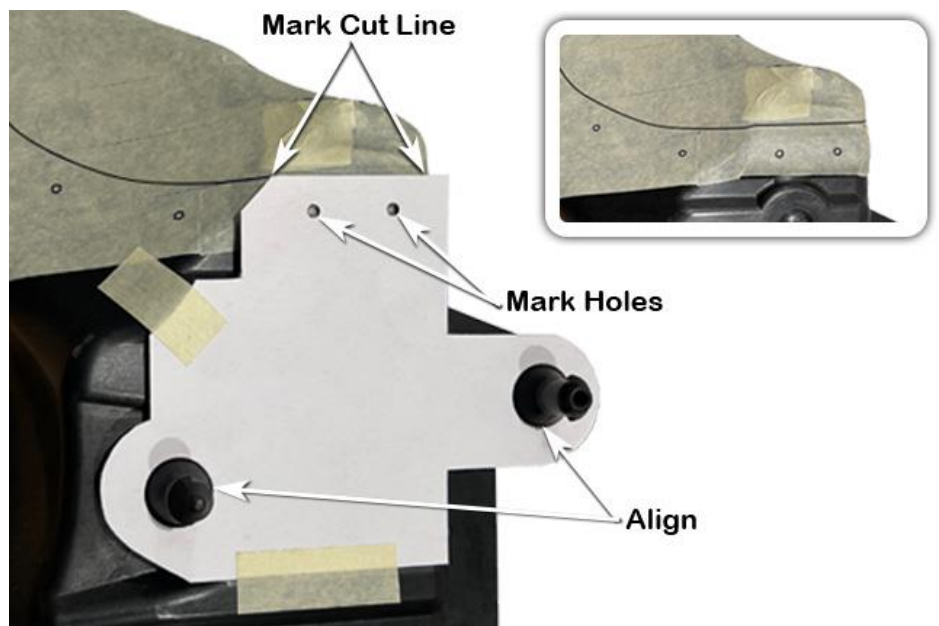

Extend the cut line under the radius from the front to the side of the air cleaner base as shown.

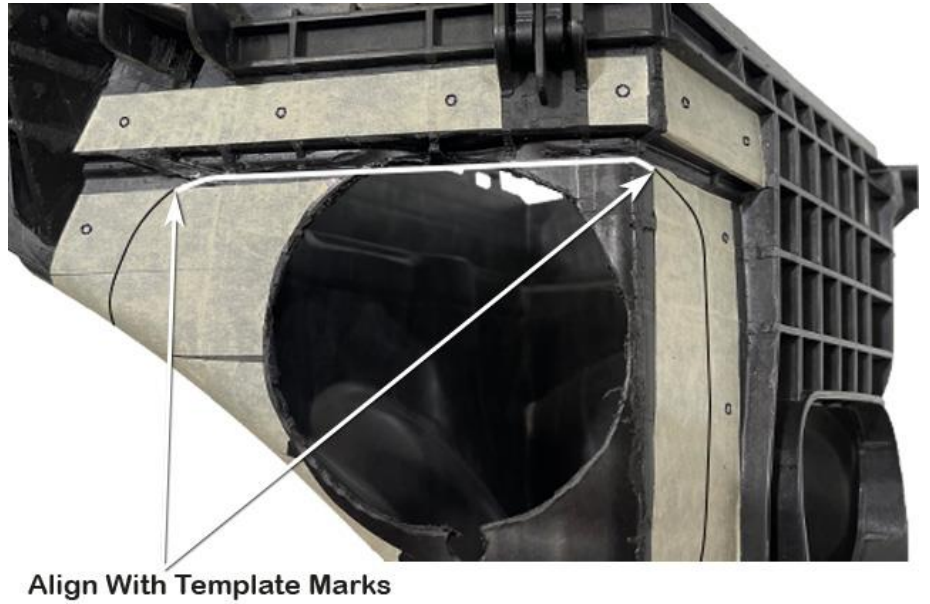

Drill a pilot hole at each of the seventeen marked hole positions, then drill the holes to 4.5mm diameter.

Deburr all holes.

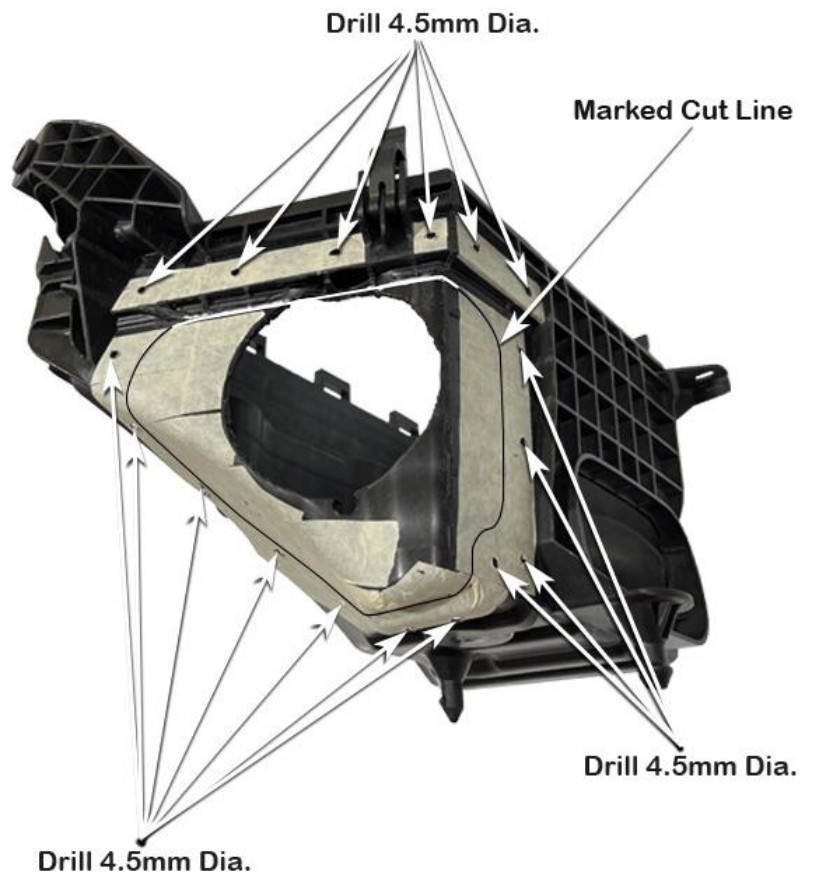

Using a body saw cut the new air cleaner inlet hole, as marked in steps 28, 29, 30, 31 & 32.

Neaten up the cut using a file or die grinder.

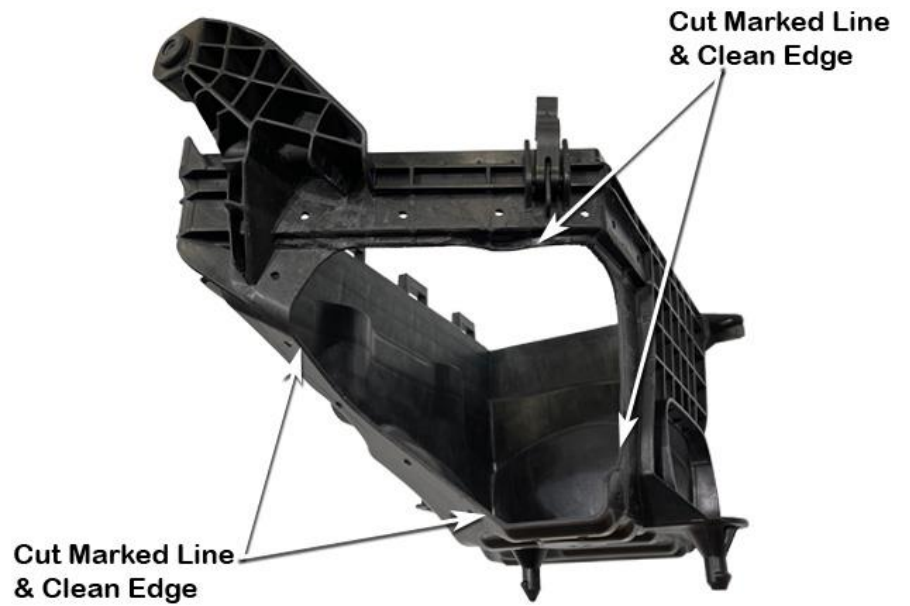

Clean up any of the remaining ribs shown with a file, sharp knife or die grinder.

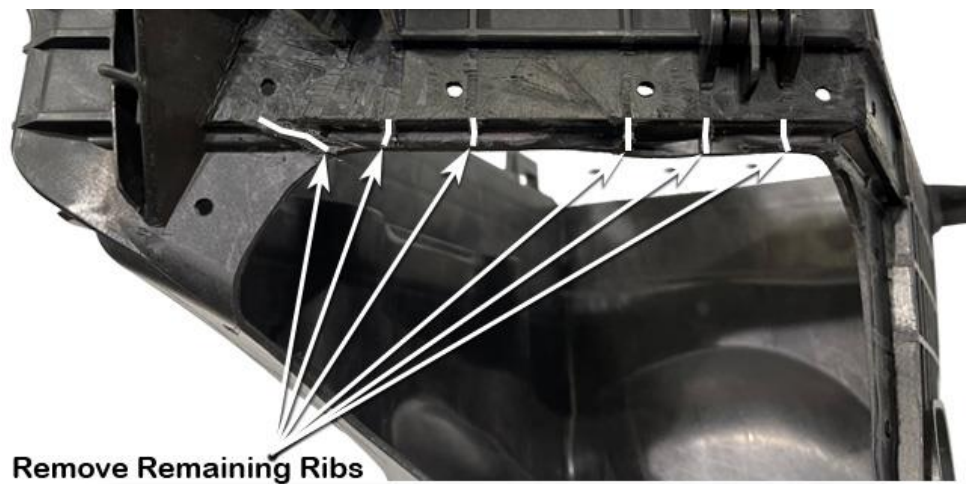

Remove Remaining Ribs

Slightly bend the lower support plate (item 15) to the curved shape of the hose as shown.

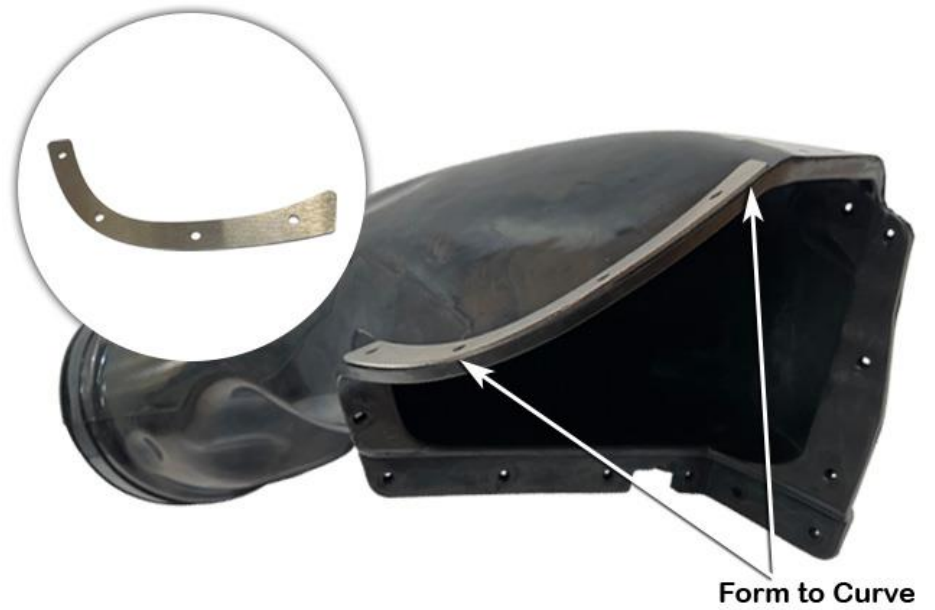

Apply a liberal amount of Sikaflex sealant to the flange of the air cleaner base.

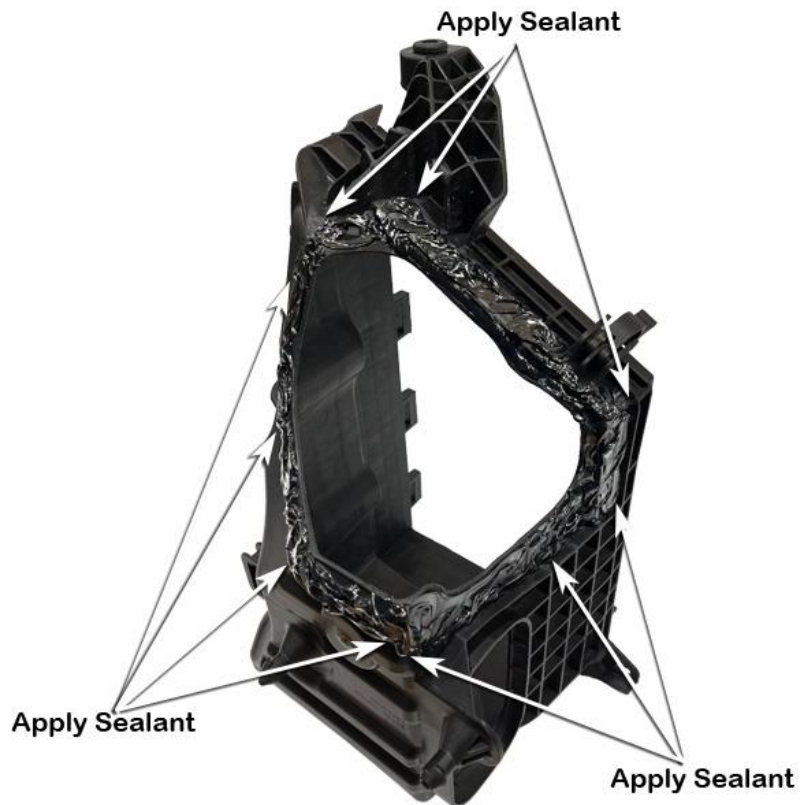

Install the air entry hose (item 10) onto the air cleaner base, install pop rivets (item 17) through the four upper side holes of the air cleaner base and hose, install the hose support plate (item 11) over the pop rivets, then using the pop rivet gun, secure the four pop rivets.

Note: Pop Rivet Orientation, all pop rivets must be installed from the inside of the air cleaner base.

Install Pop Rivets

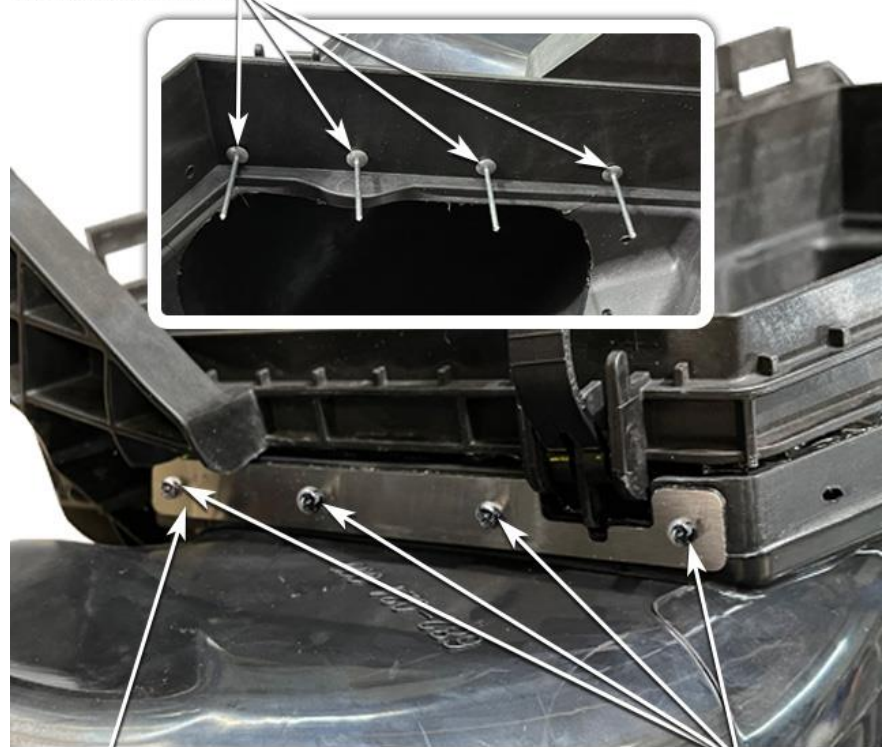

Install Plate

Secure Pop Rivets

Install pop rivets (item 17) through the two front upper holes of the air cleaner base and hose, install the hose support plate (item 12) over the pop rivets, then using the pop rivet gun, secure the two pop rivets.

Note: Pop Rivet Orientation, all pop rivets must be installed from the inside of the air cleaner base.

Install Pop Rivets

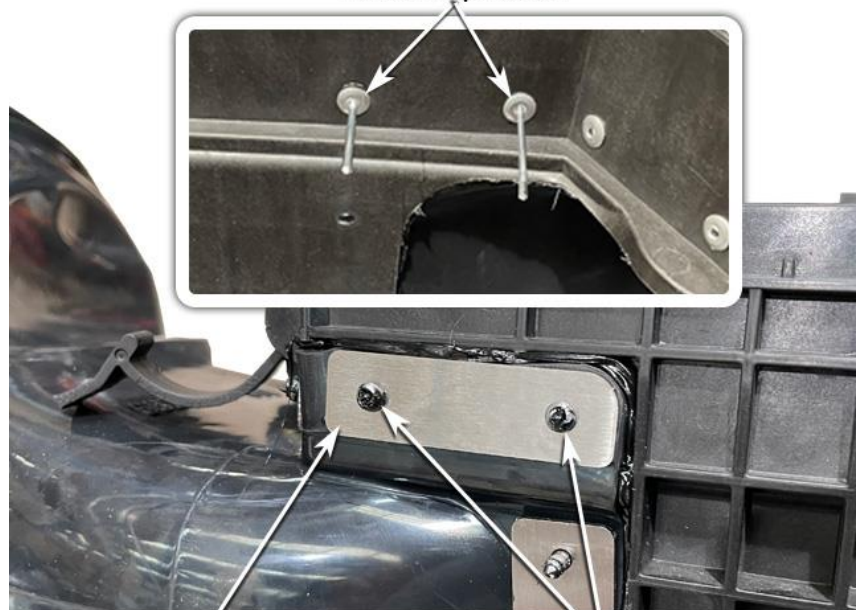

Install Plate

Secure Pop Rivets

Install pop rivets (item 17) through the four front lower holes of the air cleaner base and hose, install the hose support plate (item 13) over the pop rivets, then using the pop rivet gun, secure the four pop rivets.

Note: Pop Rivet Orientation, all pop rivets must be installed from the inside of the air cleaner base.

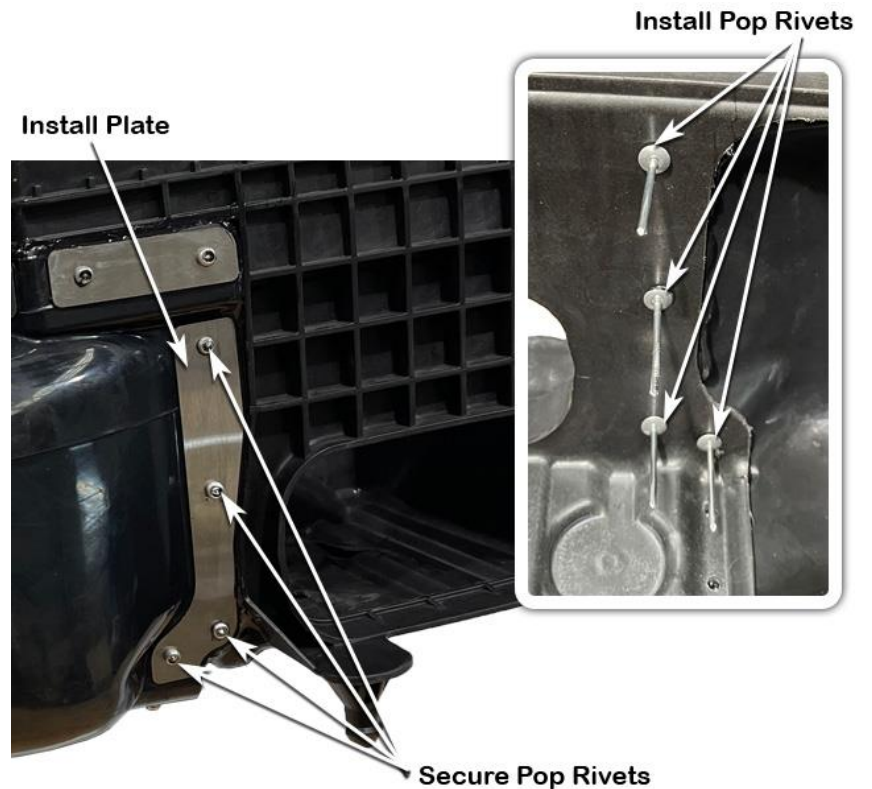

Install pop rivets (item 17) through the four lower holes of the air cleaner base and hose, install the hose support plate (item 15) over the pop rivets. then using the pop rivet gun secure the four pop rivets.

Note: Pop Rivet Orientation, all pop rivets must be installed from the inside of the air cleaner base.

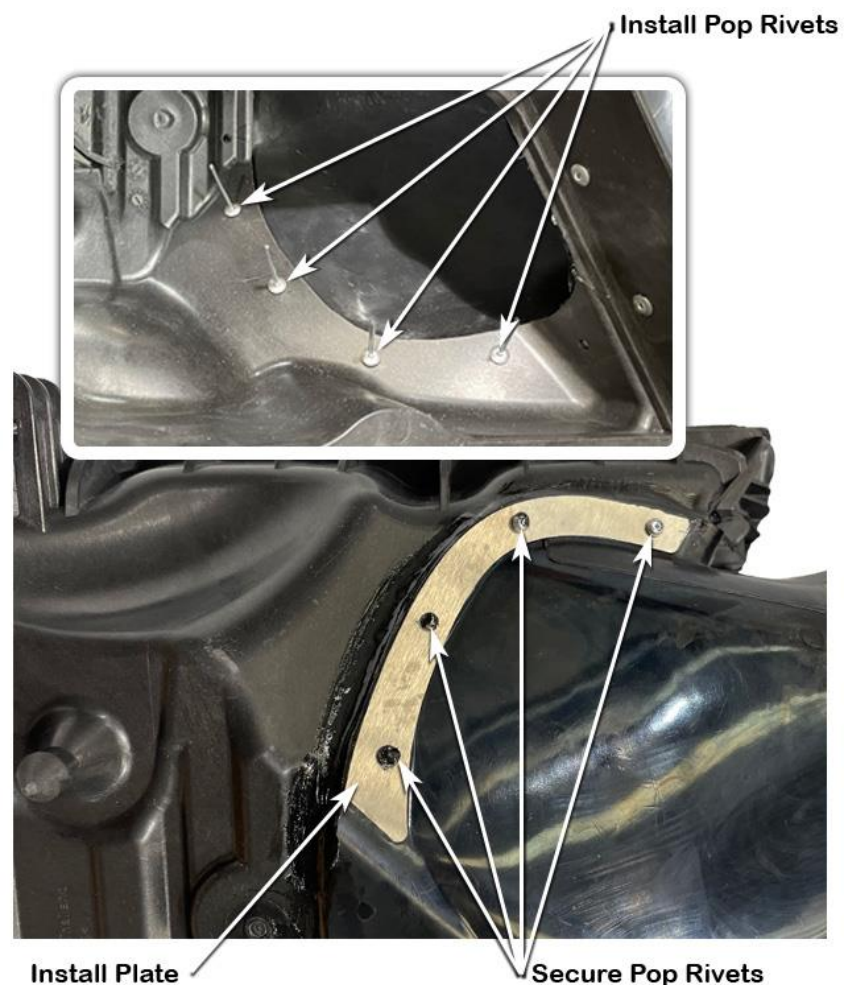

Install two 4.0mm x 16mm B/H cap screws (item 18) through the two lower holes of the air cleaner base and hose, install the hose support plate (item 14) over the two bolts, install a 4.0mm body washer (item 19) and 4.0mm nyloc nut (item 20) onto the bolts and tighten.

Note: Do not overtighten the nuts.

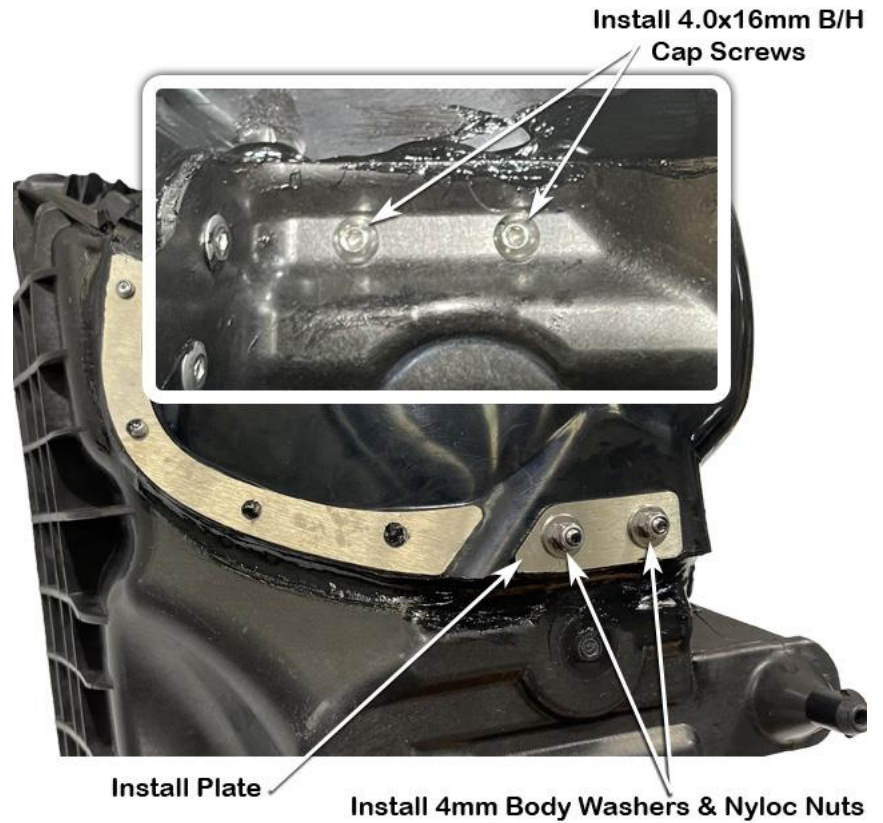

Install a 4.0mm x 16mm B/H cap screws (item 18) with a 4.0mm body washer (item 19) through the side rear hole of the air cleaner base and hose, install the hose support plate (item 16) over the bolt, install a 4.0mm body washer (item 19) and 4.0mm nyloc nut (item 20) onto the bolt and tighten.

Note: Do not overtighten the nuts.



Clean up the Sikaflex sealant on the inside and outside of the air cleaner base to ensure a neat finish, if required apply more Sikaflex sealant to any areas that require more sealant to ensure the fitment of the hose to the air cleaner base is correctly sealed.

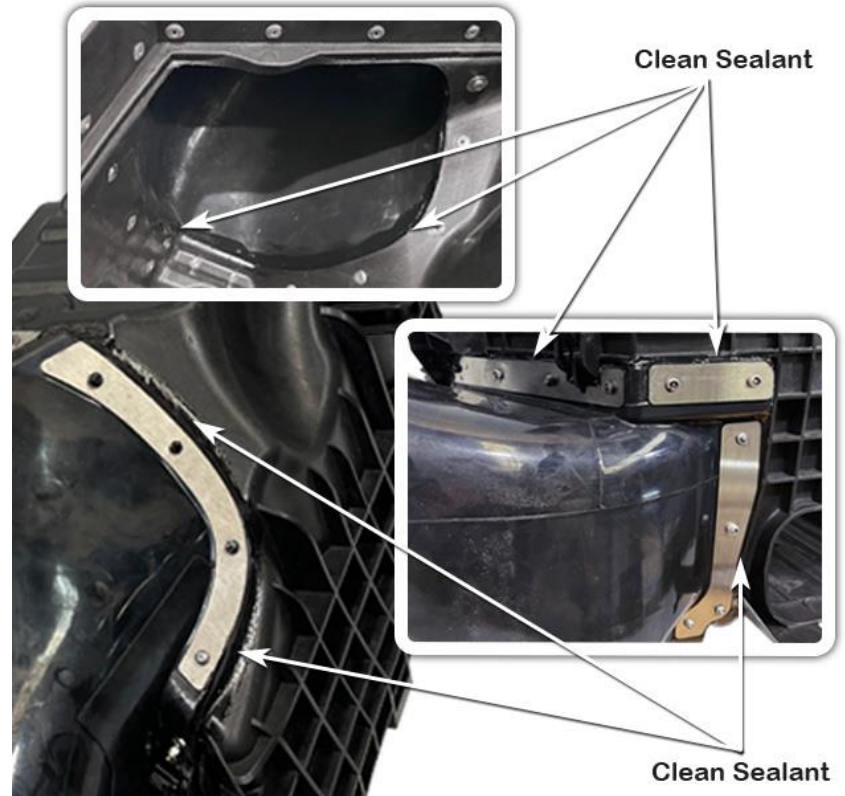

Apply Sikaflex adhesive sealant to the original air cleaner inlet hole and air inlet blank-off plug (item 21).

Install the blank-off plug into the original air cleaner inlet hole.

Ensure the blank-off plug is fully inserted into air cleaner base and blank-off plug clips are fully engaged.

Clean-up any excess sealant to ensure a neat finish.

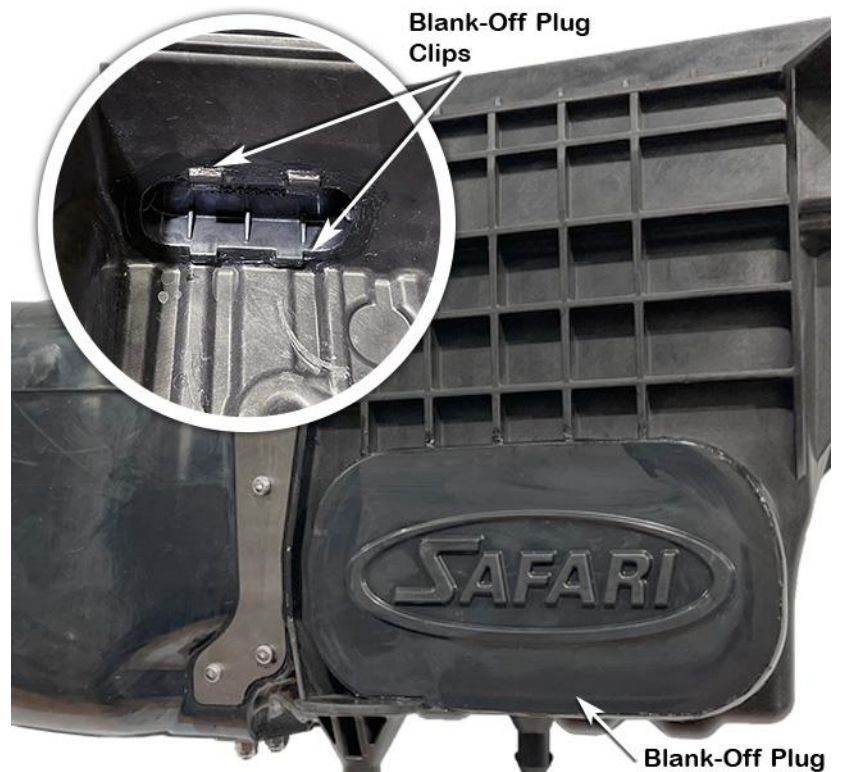

Re-install the air cleaner base into position, ensuring the mounting pins are correctly installed into the mounting grommets. Install the standard mounting bolt and fasten.

Loosely install the 120/140mm hose clamp (item 22) to the inlet of the air entry hose (item 10).

Note: The orientation of the hose clamp.

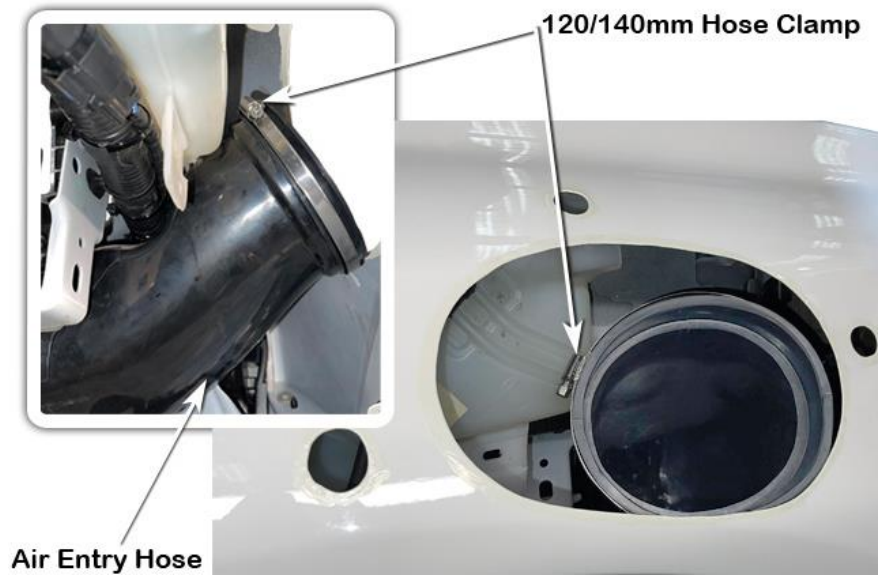

Remove the tape holding the rubber infill to the snorkel body (if fitted).

Apply a small amount of lubricant to the inside of the air entry hose (item 10).

Carefully install the snorkel body (Item 1) to the fender, guiding the snorkel body outlet into the air entry hose (item 10), align the snorkel body to fender and upper mounting bracket.

When correctly aligned, fasten the snorkel body to the fender with body washers (Item 8) and nyloc nuts (Item 9).

Fasten the snorkel body to the upper mounting bracket with hex bolts (Item 4).



With the air entry hose correctly installed onto the snorkel body outlet snout, tighten the 120/140mm hose clamp (item 22).

Note: The orientation of the hose clamp.

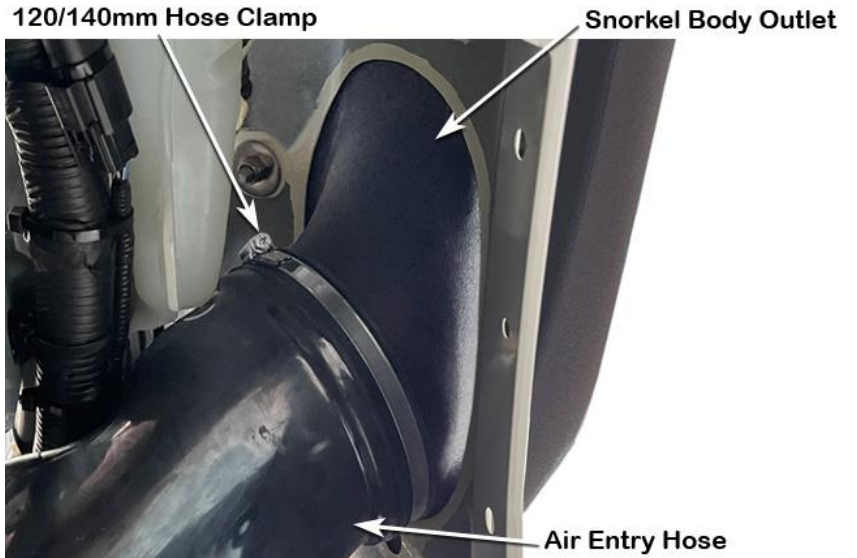

Install the ARMAX air ram assembly (item 2) onto the snorkel body. Align the ARMAX air ram assembly mount holes with the four pre-drilled 2mm holes in snorkel body inlet.

Secure the ARMAX air ram (item 2) to the Snorkel Body (item 1) with four black self tapping screws (item 23).



Re-install the RH Inner guard liner (Secondary Splash Guard Section), Front wheel arch moulding, RH Inner guard liner (Main Splash Guard Section), air cleaner element, air cleaner lid, reconnect sensor wiring and any other items that may have been removed during the snorkel installation process.

N.B: It is the installer's responsibility to ensure that all connections are watertight.